

Sathen Theiven

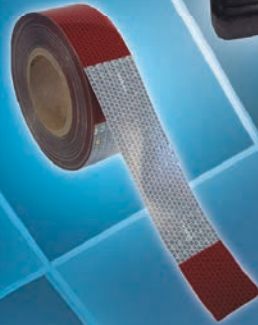

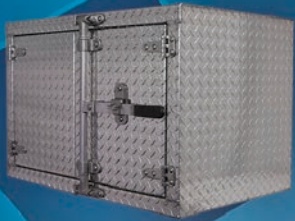









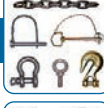

+1 647 299 3496

sathen@abmcatalyst.com

Where Innovation Meets The Road



Hardware - Cargo Control - Tool Boxes

1	Tool Boxes	
2-10	Locks	
11-13	Handles	
14-18	Hinges	
19-20	Latches and Bolts	
21	Drawer Slides	
22-24	Door Supports and Holders	
25-27	Cargo Control	
28	Adhesives and Sealants	
29-31	Rubber and Weatherstripping	
32	Mud Flaps, Floor Hardware	
33	Miscellaneous	
34	Ventilation and Heating	
35-39	Rivets	
39	Threaded Rods	



124-124



124-248



128-024

One-Door Tool Box with T-Handle

Aluminum 0.100", also available in 0.063"

Part	Depth	Height	Width
118-124	18"	18"	24"
118-136	18"	18"	36"
118-148	18"	18"	48"
118-160	18"	18"	60"
118-436	24"	18"	36"
118-448	24"	18"	48"
118-460	24"	18"	60"
124-124	24"	24"	24"
124-136	24"	24"	36"
124-148	24"	24"	48"
124-160	24"	24"	60"
124-172	24"	24"	72"
130-136	24"	30"	36"
130-148	24"	30"	48"
130-160	24"	30"	60"
130-172	24"	30"	72"
136-124	24"	36"	24"
136-136	24"	36"	36"
136-148	24"	36"	48"
136-160	24"	36"	60"
136-172	24"	36"	72"

Two-Door Tool Box with compression lock

Aluminum 0.100", also available in 0.063"

Part	Depth	Height	Width
118-236	18"	18"	36"
118-248	18"	18"	48"
118-260	18"	18"	60"
118-536	24"	18"	36"
118-548	24"	18"	48"
118-560	24"	18"	60"
124-236	24"	24"	36"
124-248	24"	24"	48"
124-260	24"	24"	60"
124-272	24"	24"	72"
130-236	24"	30"	36"
130-248	24"	30"	48"
130-260	24"	30"	60"
130-272	24"	30"	72"
136-236	24"	36"	36"
136-248	24"	36"	48"
136-260	24"	36"	60"
136-272	24"	36"	72"

Step Tool Box with T-Handle

Aluminum 0.100"

Part	Depth	Height	Width
128-012	28-1/2"	24"	12"
128-018	28-1/2"	24"	18"
128-024	28-1/2"	24"	24"



J-Boxes Tool Boxes' **custom design** are welcomed with quick lead time guaranteed.

Paddle handles

5.50" x 4.25"

Part	Finish	Specifications
225-101	Zinc	Locking CH501 with holes
225-102	Zinc	Locking CH502 with holes
225-103	Zinc	Locking CH503 with holes
225-191	Zinc	Non-Locking with holes
225-201	S/S	Locking CH501 with holes
225-202	S/S	Locking CH502 with holes
225-203	S/S	Locking CH503 with holes
225-291	S/S	Non-Locking with holes



225-201

Accessories

Part	Finish	Specifications
225-951	Plastic	Inside release knob - black
225-961	Rubber	Gasket
225-965	Neoprene	Gasket
230-531	Zinc	Striker for handle



225-951



225-961



230-531

Replacement key cylinders

Part	Finish	Specifications
235-101	Zinc	CH501
235-102	Zinc	CH502
235-103	Zinc	CH503
235-104	Zinc	CH504
235-105	Zinc	CH505



235-101

Special replacement key cylinder

Part	Finish	Specifications
237-101	Nickel	Slotted insert
237-111	Nickel	Hex insert
237-121	Nickel	Black knob
237-131	Nickel	Wing type



237-101



237-111



237-121



237-131



225-501



225-955



225-951



230-531



235-701



225-401

Junior paddle handles

4.75" x 3.625"

Part	Finish	Specifications
225-501	Zinc	Locking CH501 with holes
225-502	Zinc	Locking CH502 with holes
225-503	Zinc	Locking CH503 with holes
225-591	Zinc	Non-Locking with holes
225-521	S/S	Locking CH501 with holes
225-522	S/S	Locking CH502 with holes
225-523	S/S	Locking CH503 with holes
225-596	S/S	Non-Locking with holes

Accessories

Part	Finish	Specifications
225-951	Plastic	Inside release knob - black
225-955	Rubber	Gasket
230-531	Zinc	Striker for handle

Replacement key cylinders

Part	Finish	Specifications
235-701	Zinc	CH501
235-702	Zinc	CH502
235-703	Zinc	CH503
235-704	Zinc	CH504
235-705	Zinc	CH505

Tool Box Locks

3.25" x 3.25"

Part	Finish	Specifications
225-401	S/S	Locking CH501 with holes
225-491	S/S	Non-Locking with holes

T-Handles

4.88" x 4.75"

Part	Finish	Specifications
226-001	S/S	Locking CH501, gasket
226-002	S/S	Locking CH502, gasket
226-003	S/S	Locking CH503, gasket
226-101	S/S	Locking CH501, gasket, dust cover
226-102	S/S	Locking CH502, gasket, dust cover
226-103	S/S	Locking CH503, gasket, dust cover



226-101



226-199

Accessories

Part	Finish	Specifications
226-191	Chrome	Dust cap
226-195	Plastic	Dust cap
226-199	Neoprene	Gasket



226-191



226-195

Replacement key cylinders

Part	Finish	Specifications
235-201	Zinc	CH501
235-202	Zinc	CH502
235-203	Zinc	CH503
235-204	Zinc	CH504
235-205	Zinc	CH505



235-201

"Whale Tail" recessed T-handle

Part	Finish	Specifications
226-406	Chrome	Handle - key cylinder not included
226-451	-	Key cylinder J201 #18400DBJ201-09
226-452	-	Key cylinder J202 #18400DBJ202-09
226-453	-	Key cylinder J203 #18400DBJ203-09



226-406

Recessed D-handles

Complete kit with rods and guides

Part	Finish	Specifications
227-221	S/S	Handle 227-226, 2 rods 230-301 & 2 guides 230-501
227-241	S/S	Handle 227-246, 2 rods 230-301 & 2 guides 230-501



227-216,
227-226



227-236,
227-246

Recessed D-handles

Part	Finish	Specifications
227-216	S/S	Recessed handle - non-locking - 6-1/8" dia.
227-226	S/S	Recessed handle 2 pts - non-locking - 6-1/8" dia.
227-236	S/S	Recessed handle - Locking - 6-1/8" dia.
227-246	S/S	Recessed handle 2 pts - Locking - 6-1/8" dia.

Accessories

Part	Finish	Specifications
227-951	Rubber	Gasket for handles 227-216, 227-226
227-957	Rubber	Gasket for handles 227-236, 227-246



227-951



227-957

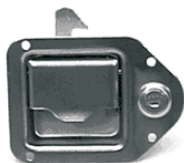

225-701

Tool Box paddle handles

4.37" x 3.27"

Part	Finish	Specifications
225-701	S/S	Locking CH501 with holes
225-791*	S/S	Non-Locking with holes
225-819	Zinc	Rod guide

* Rod guide not included



235-301

Replacement key cylinders

Part	Finish	Specifications
235-301	Zinc	CH501
235-302	Zinc	CH502
235-303	Zinc	CH503
235-304	Zinc	CH504
235-305	Zinc	CH505
235-306	Zinc	CH506
235-307	Zinc	CH507
235-308	Zinc	CH508
235-309	Zinc	CH509
235-310	Zinc	CH510



225-851 - Front view



225-851 - Rear view

"RV" paddle handles

Part	Finish	Specifications
225-851	Chrome	3.47" x 4.28", Lockable
225-853	Black	3.47" x 4.28", Lockable
225-855	White	3.47" x 4.28", Lockable



225-301



224-457

Rotary paddle handle

Part	Finish	Specifications
225-301	CH-501	Locking CH501 with holes
224-457	-	Striker

Locking paddle handle - 2 pts

Complete kit with rods and bolts

Part	Finish	Key
224-801	S/S	CH501

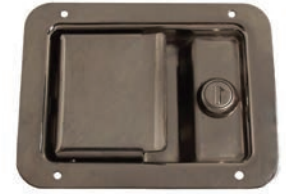
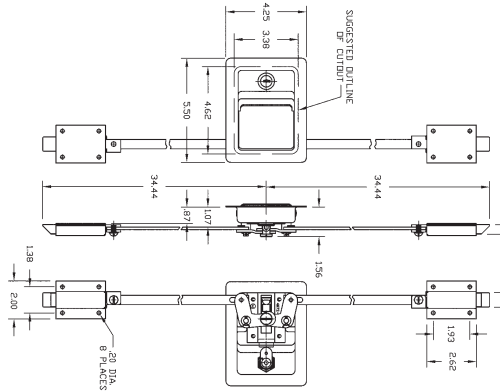

224-801

Locking T-handle

Complete kit with rods and guides

Part	Finish	Specification
226-751	S/S	Complete kit
226-771	S/S	Center only
230-511	Zinc	Rod guide
230-201	Zinc	Rod



226-751

Rods

Part	Diameter	Length
230-101	1/4"	36"
230-201	5/16"	34"
230-221	5/16"	48"
230-301	3/8"	36"
230-311	3/8"	36"
230-321	3/8"	48"



230-101



230-201
230-221



230-301
230-321



230-311

Flush Bolts

Part	Finish	Specification
240-351	Zinc	45°, for 1/4" rod
240-353	Zinc	45°, for 3/8" rod
240-361	Zinc	30°, for 1/4" rod



240-351



240-353



230-361

Guides

Part	Specification
230-501	Rod guide, zinc
230-511	Rod guide, zinc



230-501



230-511

Deadbolt Locks

3 points

Part	Specification
224-921	Zinc, 48" rods, right
224-926	Zinc, 48" rods, left



224-921



228-421



228-423



228-425



228-431



228-441



228-451, 228-461



228-491



228-461



228-463



222-621

Refrigeration handles

Part	Finish	Specification
228-421	Chrome	flush mount striker, non-locking, 4-1/2"
228-423	Chrome	flush mount striker, non-locking, 5-1/4"
228-425	Chrome	3/8" offset striker, non-locking, 6-3/4"

Dual refrigeration handle

Part	Finish	Specification
228-431	S/S	Locking, flush mount, 40" S/S bar

Refrigeration door kits

Part	Finish	Specification
228-441 *	Chrome	Ext. handle and striker included
228-451 *	Chrome	Ext/Int. handle and striker included
228-461 *	S/S	Ext/Int. handle and striker included
228-491	Plastic	Inside handle only

* Adjustable striker - 1/8" to 1/4"

High temperature handles

Part	Finish	Specification
228-481	S/S	5-1/2"
228-483	S/S	6-3/4"

Compression recessed locks

Kit, tube not included

Part	Finish	Specification
222-621	S/S	Lockable, 320mm x 165mm
222-641	S/S	Lockable, 358mm x 138mm

Cab locks

Part	Finish	Specifications
224-401	Zinc	Right side, 2" x 3.38"
224-406	Zinc	Left side, 2" x 3.38"
224-411	Zinc	Without inside release, right side, 2" x 3.38"
224-416	Zinc	Without inside release, left side, 2" x 3.38"
224-481	Zinc	With inside release, right side, 2.875" x 2.9375"
224-491	Zinc	Universal slamming, 5.375" x 3.875"
224-601	Zinc	With locking trigger, right side, 2.375" x 3.375"
224-606	Zinc	With locking trigger, left side, 2.375" x 3.375"



224-401



224-416



224-481



224-491



224-601

Off-Road vehicle hardware

Part	Finish	Specifications
228-201	Left	Cab Lock with Inside handle and striker
228-206	Right	Cab Lock with Inside handle and striker
223-001	Plastic	Push-Button Handle, reinforced with nylon, 7-1/4"
223-351	Plastic	Window Throw-Away, reinforced with nylon, 4"
202-201	Plastic	Window Hinge, reinforced with nylon, 2.68"



228-201



223-001



223-351



202-201

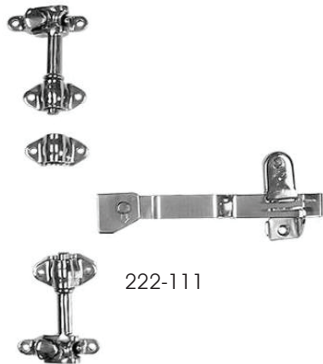

222-111

Compression Locks

Part	Finish	Specifications
222-111	S/S	22mm, 3 points - 3 rod guides
222-115	S/S	9' 6" tube, 22 mm
222-121	S/S	27mm, 2 points - 2 rod guides
222-123	S/S	27mm, 2 points - 3 rod guides
222-125	S/S	9' 6" tube, 27 mm
222-581	Aluminum	27mm, 2 points - 3 rod guides
222-589	Aluminum	10' tube, 27mm

Components for 222-111

Part	Finish	Specifications
222-940	S/S	Handle
222-941	S/S	Handle clip
222-942	S/S	Handle keeper
222-945	S/S	Rod guide
222-946	S/S	Cam
222-947	S/S	Keeper



222-121

Components for 222-121, 222-123

Part	Finish	Specifications
222-930	S/S	Handle
222-931	S/S	Handle clip
222-932	S/S	Handle keeper
222-935	S/S	Rod guide
222-936	S/S	Cam
222-937	S/S	Keeper



222-581

Components for 222-581

Part	Finish	Specifications
222-951	Aluminum	Right hand cam
222-952	Aluminum	Left hand cam
222-953	Aluminum	Keeper
222-954	Nylon	Lower bearing plate
222-955	Aluminum	Upper bearing plate
222-956	Aluminum	Handle
222-957	Aluminum	Handle keeper

Compression Locks

Part	Finish	Specifications
222-201	Steel	Complete Eberhard #1969 Anti-rack
222-451	Zinc	Dead bolt lock
222-583	Zinc	2 points, 4 rod guides
222-585	Zinc	27mm, 2 points, 3 rod guides

- Tube not included



222-583



222-585

Components for 222-201

Part	Eberhard	Specifications
222-203	1969-6X	Handle
222-205	1969-7X	Seal pin
222-207	1969-4X	Seal plate
222-209	1969-39	Bushing
222-211	1-1969-5	Handle clip
222-213	1969-10	Middle rod bracket cover - top
222-215	1969-11	Middle rod bracket cover - bottom
222-217	1969-8	Bearing cover - back plate - top
222-219	1969-9X	Bearing cover - back plate - bottom
222-221	1969-2X	Cam
222-223	1969-1	Keeper
222-225	5625-16	Bolt
222-227	5625-17	Locknut



222-201



222-451

Components for 222-583

Part	Finish	Specifications
222-985	Zinc	Handle
222-987	Zinc	Handle keeper



222-985



222-987

Cargo-Vise locks

Part	Finish	Specifications
222-051	Aluminum	Lockable, gray
222-801	-	Key cylinder #301
222-802	-	Key cylinder #302
222-803	-	Key cylinder #303
222-804	-	Key cylinder #304
222-805	-	Key cylinder #305
222-806	-	Key cylinder #306
222-807	-	Key cylinder #307
222-808	-	Key cylinder #308
222-809	-	Key cylinder #309
222-810	-	Key cylinder #310



222-051

Grab handles



221-106

Part	Finish	Specifications
221-101	Aluminum	13" O.D., 4 holes
221-106	Zinc	13" O.D., 4 holes



221-186

Part	Finish	Specifications
221-186	Zinc	13" O.D., 2 holes
221-196	Chrome	13" O.D., 2 holes



221-301

Part	Finish	Specifications
221-301	S/S	11-1/2" O.D., 4 holes
221-311	S/S	28" O.D., 4 holes



221-201



221-211

Part	Finish	Specifications
221-201	Chrome	7" C.-C., 4 holes
221-203	Caoutchouc	Joint pour 221-201
221-211	Chrome	5" C.-C., 4 holes



221-851

Part	Finish	Specifications
221-851	Plastic	8" C.-C., 2 holes



221-708

Part	Finish	Specifications
221-708	Zinc	5-1/2" C.-C., 4 holes

Grab handles

Part	Finish	Specifications
221-901	Black	6-1/4" C.-C., 7-1/2" O.D.
221-911	Black	9-3/4" C.-C., 11" O.D.



221-901

Part	Finish	Specifications
221-521	Black	18.31"



221-521

Part	Finish	Specifications
220-801	Plain steel	4", holes 3.90" C.-C.
220-806	Zinc	4", holes 3.90" C.-C.
220-821	S/S	4-5/16", holes 3.90" C.-C.



220-821

Part	Finish	Specifications
229-106	S/S	3-1/2" base, 4-5/16" handle
229-121	Zinc	4" base, 4" handle



229-106



229-121

L-Handles

Part	Finish	Specifications
220-501	Chrome	Locking, front mount, dust shutter, with gasket, 1-3/4" c.c., 3" shaft
220-503	Chrome	Locking, front mount, dust shutter, with gasket, 1-1/2" c.c., 3" shaft
220-507	Chrome	Non-locking, front mount, with gasket, 1-1/2" c.c., 3" shaft
220-509	Chrome	Non-locking, front mount, with gasket, 1-3/4" c.c., 3" shaft
220-905	Chrome	Interior handle, 4-1/8", for 5/16" shaft
220-911	Zinc	Inside handle with set screw, 5-1/2", for 5/16" shaft
223-101	Chrome	Locking, no dust shutter, 1-1/2" c.c., 4" shaft
223-103	Chrome	Locking, no dust shutter, 1-3/4" c.c., 4" shaft
223-105	Chrome	Locking, no dust shutter, free rotation when locked, 1-1/2" c.c., 4" shaft
223-111	Chrome	Locking, no dust shutter, blind mount, 1-13/16" c.c., 4" shaft
223-121	Chrome	Non-locking, 1-3/4" c.c., 4" shaft



220-503



220-507



220-905



223-101



223-103



223-105



223-111



223-121

T-Handles

Part	Finish	Specifications
223-201	Steel black	Locking, with dust cover, 1-1/2" c.c., 4" shaft
223-203	Chrome	Locking, no dust cover, 1-1/2" c.c., 4" shaft
223-205	Chrome	Locking, with dust cover, 1-1/2" c.c., 4" shaft
223-207	Chrome	Locking, no dust cover, 1-3/4" c.c., 4" shaft
223-221	Chrome	Non-locking, 1-1/2" c.c., 4" shaft



223-201



223-203



223-205



223-207



223-221

Latch

Part	Finish	Specifications
230-521	Zinc	Adjustable Latch with screw for 5/16" square shank



230-521

Steel piano hinges

Part	Length	Width	Thickness	Pin diameter	Rod material	Knuckles
210-105	72"	1-1/16"	0.042"	0.091"	Steel	1/2"
210-111	72"	1-1/2"	0.060"	0.120"	Steel	1/2"
210-201	72"	2"	0.060"	0.187"	Steel	1"
210-203	72"	2"	0.060"	0.187"	Brass	1"
210-205	72"	2"	0.072"	0.250"	Steel	1"
210-207	73.5"	2"	0.090"	0.250"	Brass	1-3/4"
210-301	72"	3"	0.072"	0.250"	Steel	1"
210-303	72"	3"	0.078"	0.250"	Brass	1"
210-501	72"	5"	0.125"	0.375"	Steel	2"

- Other models available. contact us for more details

Aluminum piano hinges

Part	Length	Width	Thickness	Pin diameter	Rod material	Knuckles
212-101	72"	1-1/2"	0.041"	0.091"	Aluminum	1/2"
212-201	72"	2"	0.064"	0.120"	Aluminum	1/2"
212-303	72"	3"	0.064"	0.125"	Aluminum	1/2"

- Other models available. contact us for more details

Stainless Steel piano hinges

Part	Length	Width	Thickness	Pin diameter	Rod material	Knuckles
213-101	72"	1-1/16"	0.035"	0.086"	S/S	1/2"
213-103	72"	1-1/2"	0.035"	0.086"	S/S	1/2"
213-105	72"	1-1/2"	0.060"	0.120"	S/S	1/2"
213-201	72"	2"	0.060"	0.120"	S/S	1/2"
213-205	72"	2"	0.060"	0.187"	S/S	1"
213-301	84"	3"	0.060"	0.187"	S/S	1"
213-303	96"	3"	0.072"	0.250"	S/S	1"

- Other models available. contact us for more details

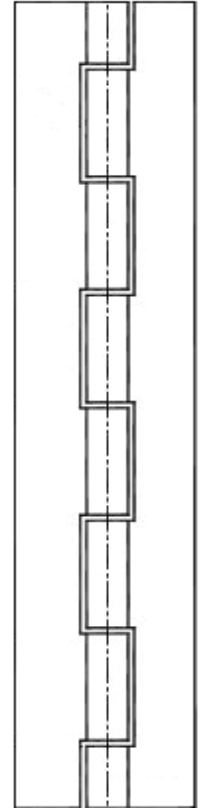

Plain steel weld-on hinges

Part	Finish	Specifications
203-001	Aluminum	1/2" pin, 4,75" x 5,00" x 0,188"
203-201	Plain steel	3/8" pin, 4", type O
203-251	Plain steel	1/2" pin, 3-3/4", type P
203-261	Plain steel	1/2" pin, 4", type P
203-271	Plain steel	1/2" pin, 4-1/2", type P
203-283	Plain steel	1/2" pin, 2-1/2", Knurled Pin
203-701	Plain steel	3-1/4" with grease fitting
203-706	Plain steel	5-1/4" with grease fitting

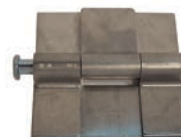

203-001



202-201, 203-251
203-261, 203-271
203-283



203-701, 203-706



215-100
216-100



215-200
216-200

215 Series | Profile (Steel), Pin (Steel), Washers (Brass)

216 Series | Profile (Steel), Pin (Brass), Washers (Brass)

Steel Pin	Grease Fitting	Brass Pin	Grease Fitting	Dimensions		Box Qty.
215-101	-	216-101	-	40 mm	1-9/16"	20
215-104	-	216-104	-	50 mm	2"	20
215-109	-	216-109	-	60 mm	2-3/8"	20
215-112	-	216-112	-	70 mm	2-3/4"	20
215-117	215-217	216-117	216-217	80 mm	3-3/16"	20
215-120	215-220	216-120	216-220	100 mm	4"	20
215-125	215-225	216-125	216-225	120 mm	4-3/4"	20
215-128	215-228	216-128	216-228	135 mm	5-1/4"	10
215-133	215-233	216-133	216-233	150 mm	6"	10
215-136	215-236	216-136	216-236	180 mm	7"	10
215-141	215-241	216-141	216-241	200 mm	8"	10
-	215-244	-	-	260 mm	10"	10



218-100



218-200

218 Series | Profile(S/S), Pin(S/S), Washers(S/S)

S/S 304	Dimensions		Box Qty.
218-109	60 mm	2-3/8"	20
218-117	80 mm	3-3/16"	20
218-120	100 mm	4"	20
218-125	120 mm	4-3/4"	20
218-133	150 mm	6"	10
218-136	180 mm	7"	10
218-141	200 mm	8"	10

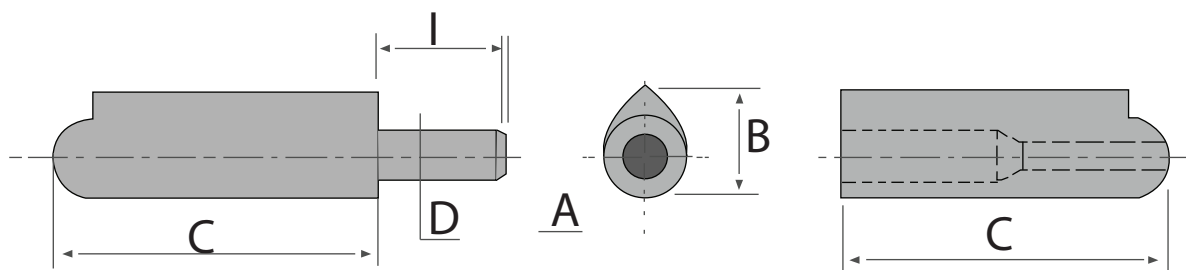

mm	Dimension (")	A	B	C	D	I
260	10"	28	32	129	19	-
200	8"	23	28,5	98,5	16	-
180	7"	20	25	88,6	14	-
150	6"	20	25	73,6	13	-
135	5-1/4"	18	22	66,3	12	-
120	4-3/4"	16	20	58,9	11	-
100	4"	16	20	48,9	10	-
80	3-3/16"	13	15,5	39,1	8	-
70	2-3/4"	11,5	13,5	34,1	6	-
60	2-3/8"	10	12	29	6	-
50	2"	8	9,5	24	5	-
40	1-9/16"	8	9,5	19	5	-

915 Series | Profile (Steel), Pin (Steel), Washers (Brass)

916 Series | Profile (Steel), Pin (Brass), Washers (Brass)

Steel Pin	Grease Fitting	Brass Pin	Grease Fitting	Dimensions		Box Qty.
915-101	-	916-101	-	40 mm	1-9/16"	50
915-104	-	916-104	-	50 mm	2"	50
915-109	-	916-109	-	60 mm	2-3/8"	50
915-112	-	916-112	-	70 mm	2-3/4"	25
915-117	915-217	916-117	916-217	80 mm	3-3/16"	25
915-120	915-220	916-120	916-220	100 mm	4"	25
915-125	915-225	916-125	916-225	120 mm	4-3/4"	25
915-128	915-228	916-128	916-228	135 mm	5-1/4"	25
915-133	915-233	916-133	916-233	150 mm	6"	25
915-136	915-236	916-136	916-236	180 mm	7"	25
915-141	915-241	916-141	916-241	200 mm	8"	25
915-144	915-244	-	-	260 mm	10-1/4"	25



915-100
916-100



915-200
916-200



917-100



917-200

917 Series | Profile(Aluminum), Pin(S/S), Washers(S/S)

918 Series | Profile(S/S), Pin(S/S), Washers(S/S)

Aluminum	Grease Fitting	S/S 304	Dimensions		Box Qty.
917-109	-	-	60 mm	2-3/8"	50
917-117	917-217	918-117	80 mm	3-3/16"	25
917-120	917-220	918-120	100 mm	4"	25
917-125	917-225	918-125	120 mm	4-3/4"	25
917-133	917-233	918-133	150 mm	6"	25
917-136	917-236	918-136	180 mm	7"	25
917-141	917-241	918-141	200 mm	8"	25



918-100

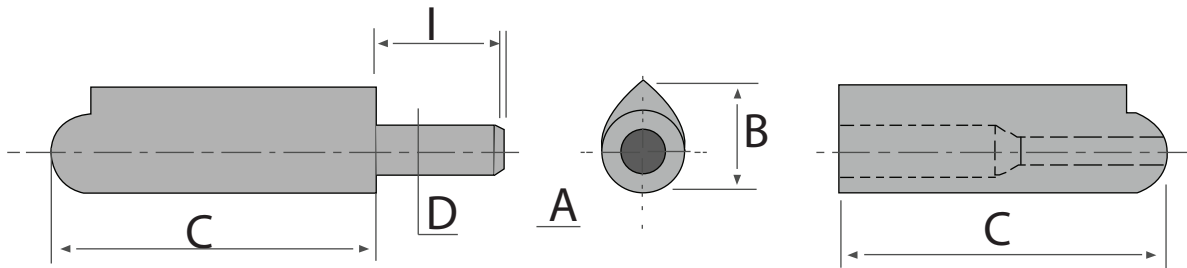

mm	Dimension (")	A	B	C	D	I
260	10"	28	32	129	19	72
200	8"	23	29	98	14	43
180	7"	20	25	88	13	40
150	6"	20	25	73	13	35
135	5-1/4"	18	22	65,5	10	35
120	4-3/4"	16	20	58,5	9	30
100	4"	16	20	48,5	7	30
80	3-3/16"	13	16	38,8	6	22
70	2-3/4"	11,5	13,5	33,8	5,5	20
60	2-3/8"	10	12	29	6	20
50	2"	8	10	24	5	15
40	1-9/16"	8	10	19	5	15



202-120



202-211



202-221



202-231



202-241



202-251, 202-253
202-255, 202-257



202-261, 202-265



202-301



204-508



204-801



204-806



204-821



204-826



204-841



204-846

Stainless Steel hinges

Part	Finish	Specifications
202-120	S/S 304	4.75"
202-211	S/S 304	2.36" x 2.32", 4mm thickness
202-221	S/S 304	4.13"
202-231	S/S 304	4.50"
202-241	S/S 304	4.25"
202-251	S/S 304	3.15", square holes
202-253	S/S 304	3.15", square holes
202-255	S/S 304	4.92", square holes
202-257	S/S 304	4.92", square holes
202-261	S/S 304	3.50", square holes
202-265	S/S 304	5.00", square holes
202-301	S/S 304	5.50"

Stainless Steel Strap Hinge

Part	Finish	Specifications
204-508	S/S 304	8.2" x 2"

Stainless Steel Heavy Duty Hinges

Part	Finish	Specifications
204-801	S/S 304	259mm x 81mm, standard butt
204-806	S/S 304	259mm x 81mm, square butt
204-821	S/S 304	321mm x 85mm, standard butt
204-826	S/S 304	321mm x 85mm, square butt
204-841	S/S 304	327mm x 85mm, standard butt
204-846	S/S 304	327mm x 85mm, square butt

Aluminum strap hinges

Part	Finish	Specifications
204-404	Aluminum	3.75"
204-418	Aluminum	8", 3 holes butt, 270°
204-412	Aluminum	12", 270°
204-728	Aluminum	16"



204-404



204-418



204-412



204-728

Zinc plated strap hinges

Part	Finish	Specifications
204-108	Zinc	8", standard butt
204-112	Zinc	12", standard butt
204-116	Zinc	16", standard butt
204-308	Zinc	8", 3 holes butt
204-312	Zinc	12", 3 holes butt
204-316	Zinc	16", 3 holes butt



204-108



204-308

Zinc plated hinges

Part	Finish	Specifications
202-216	Zinc	2.36" x 2.32", 4mm thickness
204-901	Zinc	5", right, Eberhard 5867-E1
202-601	Zinc	8.75", heavy-duty, Eberhard 5884



202-216

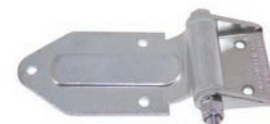

204-901



202-601



240-101

240-106

240-111



240-121



240-151



240-306

Latches

Part	Finish	Specifications
240-101	Zinc	1/2" pin, 6.300" O.D.
240-103	S/S	1/2" pin, 6.300" O.D.
240-106	Zinc	1/2" pin, 4" handle - 6.30"
240-111	Zinc	1/2" pin, 8.750" O.D.
240-121	Zinc	5/8" pin, 9.500" O.D.
240-151	Zinc	3/8" pin, 5.125" O.D.
240-306	Zinc	2" x 1.62", 4 holes



242-101

242-141

242-131

242-151

242-181

242-191

Hood latches

Part	Finish	Specifications
242-101	Rubber + zinc	2-1/2"
242-106	Rubber + S/S	2-1/2"
242-111	Rubber + zinc	3-1/2"
242-116	Rubber + S/S	3-1/2"
242-131	Rubber + zinc	5"
242-136	Rubber + S/S	5"
242-141	Rubber + zinc	6"
242-151	Rubber + zinc	8"
242-181	Steel, black	-
242-191	Steel, black	-



241-101



241-401

Catch & striker

Part	Finish	Specifications
241-101	Zinc	Straight base
241-401	Zinc	Striker



410-021



410-091

410-101,
410-106

410-111



410-121



410-131

Tie Downs

Part	Finish	Specifications
410-021	Zinc	400 lbs., ins. dia. 1-1/2"
410-091	Zinc	1200 lbs., 4"
410-101	Zinc	1200 lbs., 3-1/2" x 5"
410-106	Zinc	1200 lbs., 3-1/2" x 5"
410-111	Zinc	2000 lbs., 3-3/4" x 4"
410-121	Zinc	5000 lbs., 4-1/2" x 4-7/8"
410-131	Zinc	6000 lbs., 6-1/4" dia.



410-201

410-203, 410-205
410-207

410-211



410-213

Forged D-ring with bracket

Part	Finish	Specifications
410-201	Zinc Plated	1/2", W.L.L. 3 666 lbs., B.S. 11 000 lbs.
410-203	Plain steel	1/2", W.L.L. 3 666 lbs., B.S. 11 000 lbs.
410-205	Plain steel	5/8", W.L.L. 6 000 lbs., B.S. 18 000 lbs.
410-207	Plain steel	3/4", W.L.L. 8 833 lbs., B.S. 26 500 lbs.
410-211	Plain steel	1", W.L.L. 15 586 lbs., B.S. 46 760 lbs.
410-213	Plain steel	1", W.L.L. 15 333 lbs., B.S. 46 000 lbs.

Adjustable Latches

Part	Finish	Specifications
243-101	Zinc	3.5", locking
243-106	S/S	3.5", locking
243-111	Zinc	3.5", non-locking
243-116	S/S	3.5", non-locking
243-141	Zinc	4.7", locking
243-146	S/S	4.7", locking
243-171	Zinc	6.4", locking
243-176	S/S	6.4", locking



Strikers for adjustable latches

Part	Finish	Specifications
243-121	Zinc	Striker for 3.5"
243-126	S/S	Striker for 3.5"
243-131	Zinc	Striker for 3.5"
243-136	S/S	Striker for 3.5"
243-161	Zinc	Striker for 4.7"
243-166	S/S	Striker for 4.7"
243-191	Zinc	Striker for 6.4"
243-196	S/S	Striker for 6.4"



Over center latches

Part	Finish	Specifications
240-201	Zinc	9-3/8", ext. 10-3/8" max
240-221	Zinc	8-3/4", ext. 9-1/2" max



J-Hooks

Part	Finish	Specifications
410-306	Zinc	3", 2 holes 0.26" dia.
410-321	Zinc	2", 2 holes 0.20" dia.



Rack Fastener

Part	Finish	Specifications
203-801	Zinc	Left, 3"
203-806	Zinc	Right, 3"
203-821	Zinc	Eye



Tarp Straps

Part	Finish	Specifications
465-100	Zinc	Replacement S-hooks
465-109	Rubber	9"
465-115	Rubber	15"
465-121	Rubber	21"
465-131	Rubber	31"
465-141	Rubber	41"



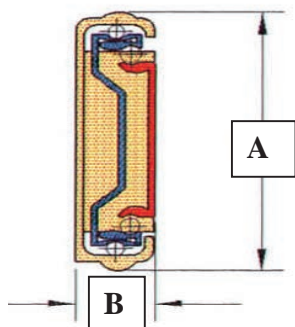

Full Extension Slides

Part	Lock'in, Lock'out Part	Lenght	A	B	Capacity
323-110	-	10"	1.85"	0.500"	100 lbs
323-112	-	12"	1.85"	0.500"	100 lbs
323-114	-	14"	1.85"	0.500"	100 lbs
323-116	-	16"	1.85"	0.500"	100 lbs
323-118	-	18"	1.85"	0.500"	100 lbs
323-120	-	20"	1.85"	0.500"	100 lbs
323-122	-	22"	1.85"	0.500"	100 lbs
323-124	-	24"	1.85"	0.500"	100 lbs
323-126	-	26"	1.85"	0.500"	100 lbs
323-128	-	28"	1.85"	0.500"	100 lbs
323-210	-	10"	1.95"	0.500"	150 lbs
323-212	-	12"	1.95"	0.500"	150 lbs
323-214	-	14"	1.95"	0.500"	150 lbs
323-216	-	16"	1.95"	0.500"	150 lbs
323-218	-	18"	1.95"	0.500"	150 lbs
323-220	-	20"	1.95"	0.500"	150 lbs
323-222	-	22"	1.95"	0.500"	150 lbs
323-224	-	24"	1.95"	0.500"	150 lbs
323-310	-	10"	2.09"	0.750"	250 lbs
323-312	-	12"	2.09"	0.750"	250 lbs
323-314	-	14"	2.09"	0.750"	250 lbs
323-316	-	16"	2.09"	0.750"	250 lbs
323-318	-	18"	2.09"	0.750"	250 lbs
323-320	-	20"	2.09"	0.750"	250 lbs
323-322	-	22"	2.09"	0.750"	250 lbs
323-324	-	24"	2.09"	0.750"	250 lbs
323-326	-	26"	2.09"	0.750"	250 lbs
323-328	-	28"	2.09"	0.750"	250 lbs
323-330	-	30"	2.09"	0.750"	250 lbs
323-332	-	32"	2.09"	0.750"	250 lbs
323-334	-	34"	2.09"	0.750"	250 lbs
323-336	-	36"	2.09"	0.750"	250 lbs
323-508	-	8"	3.00"	0.750"	up to 500 lbs
323-510	-	10"	3.00"	0.750"	up to 500 lbs
323-512	323-612	12"	3.00"	0.750"	up to 500 lbs
323-514	323-614	14"	3.00"	0.750"	up to 500 lbs
323-516	323-616	16"	3.00"	0.750"	up to 500 lbs
323-518	323-618	18"	3.00"	0.750"	up to 500 lbs
323-520	323-620	20"	3.00"	0.750"	up to 500 lbs
323-522	323-622	22"	3.00"	0.750"	up to 500 lbs
323-524	323-624	24"	3.00"	0.750"	up to 500 lbs
323-526	323-626	26"	3.00"	0.750"	up to 500 lbs
323-528	323-628	28"	3.00"	0.750"	up to 500 lbs
323-530	-	30"	3.00"	0.750"	up to 500 lbs
323-532	-	32"	3.00"	0.750"	up to 500 lbs
323-534	-	34"	3.00"	0.750"	up to 500 lbs
323-536	323-636	36"	3.00"	0.750"	up to 500 lbs
323-538	-	38"	3.00"	0.750"	up to 500 lbs
323-540	-	40"	3.00"	0.750"	up to 500 lbs
323-542	-	42"	3.00"	0.750"	up to 500 lbs
323-548	323-648	48"	3.00"	0.750"	up to 500 lbs
323-560	-	60"	3.00"	0.750"	up to 500 lbs



323-1XX, detachable



323-2XX, detachable



323-3XX, detachable



323-5XX



323-6XX - Lock'in, Lock'out

Door holders

Part	Finish	Specifications
251-111	Zinc	4" kit
251-121	S/S	4" kit
251-401	S/S	Heavy duty 4" kit
251-131	Zinc	6" kit
251-141	S/S	6" kit
251-145	Zinc	10" kit
251-148	S/S	10" kit
251-151	Zinc	Receptacle only with spring
251-161	S/S	Receptacle only with spring



251-121



251-401

Part	Finish	Specifications
251-201	Zinc	1.5", 1.25" C.-C.
251-206	S/S	1.5", 1.25" C.-C.
251-211	Zinc	2.5", 1.25" C.-C.
251-216	S/S	2.5", 1.25" C.-C.
251-221	Zinc	3.5", 1.25" C.-C.
251-226	S/S	3.5", 1.25" C.-C.
251-231	Zinc	4.5", 1.25" C.-C.
251-236	S/S	4.5", 1.25" C.-C.
251-241	Nylon	White receptacle
251-243	Nylon	Black receptacle



251-221



251-241



251-243

Part	Finish	Specifications
251-311	Aluminium	2-1/8", male
251-321	Aluminium	2-5/8", male
251-351	Aluminium	3-3/8", Receptacle



251-311, 251-321



251-351

Part	Finish	Specifications
254-151	Rubber+Plast	Kit - 2 pieces



254-151

Part	Finish	Specifications
254-501	Alum. alloy	3", gaskets included



254-501

Part	Finish	Specifications
251-171	Zinc	Kit - 3 pieces
251-181	Plain steel	-



251-171



251-181

Part	Finish	Specifications
251-501	S/S	Door retainer



251-501

Gas springs



Part	Force	Dimension	Stroke	End Fitting
281-022	22 lbs (98N)	9.8" (250mm) - 6.7" (170mm)	3.1" (80mm)	Plastic, 10 mm
281-050	50 lbs (222N)	9.8" (250mm) - 6.7" (170mm)	3.1" (80mm)	Plastic, 10 mm
281-100	100 lbs (445N)	9.8" (250mm) - 6.7" (170mm)	3.1" (80mm)	Plastic, 10 mm
Part	Force	Dimension	Stroke	End Fitting
283-013	13 lbs (58N)	12.2" (310mm) - 8.3" (210mm)	3.9" (100mm)	Plastic, 10 mm
283-035	35 lbs (156N)	12.2" (310mm) - 8.3" (210mm)	3.9" (100mm)	Plastic, 10 mm
283-065	65 lbs (289N)	12.2" (310mm) - 8.3" (210mm)	3.9" (100mm)	Plastic, 10 mm
283-100	100 lbs (445N)	12.2" (310mm) - 8.3" (210mm)	3.9" (100mm)	Plastic, 10 mm
Part	Force	Dimension	Stroke	End Fitting
285-013	13 lbs (58N)	12.5" (317mm) - 8.25" (209,5mm)	4.25" (108mm)	Plastic, 10 mm
285-030	30 lbs (142N)	12.5" (317mm) - 8.25" (209,5mm)	4.25" (108mm)	Plastic, 10 mm
285-060	60 lbs (278N)	12.5" (317mm) - 8.25" (209,5mm)	4.25" (108mm)	Plastic, 10 mm
285-090	90 lbs (400N)	12.5" (317mm) - 8.25" (209,5mm)	4.25" (108mm)	Plastic, 10 mm
285-120	120 lbs (545N)	12.5" (317mm) - 8.25" (209,5mm)	4.25" (108mm)	Plastic, 10 mm
Part	Force	Dimension	Stroke	End Fitting
287-035	35 lbs (156N)	17.1" (435mm) - 10.8" (275mm)	6.3" (160mm)	Plastic, 10 mm
287-045	45 lbs (200N)	17.1" (435mm) - 10.8" (275mm)	6.3" (160mm)	Plastic, 10 mm
287-060	60 lbs (267N)	17.1" (435mm) - 10.8" (275mm)	6.3" (160mm)	Plastic, 10 mm
287-080	80 lbs (356N)	17.1" (435mm) - 10.8" (275mm)	6.3" (160mm)	Plastic, 10 mm
287-097	97 lbs (432N)	17.1" (435mm) - 10.8" (275mm)	6.3" (160mm)	Plastic, 10 mm
287-135	135 lbs (600N)	17.1" (435mm) - 10.8" (275mm)	6.3" (160mm)	Plastic, 10 mm
Part	Force	Dimension	Stroke	End Fitting
289-030	30 lbs (142N)	18" (457mm) - 10.5" (267mm)	7.5" (190,5mm)	Plastic, 10 mm
289-060	60 lbs (278N)	18" (457mm) - 10.5" (267mm)	7.5" (190,5mm)	Plastic, 10 mm
289-090	90 lbs (400N)	18" (457mm) - 10.5" (267mm)	7.5" (190,5mm)	Plastic, 10 mm
289-120	120 lbs (545N)	18" (457mm) - 10.5" (267mm)	7.5" (190,5mm)	Plastic, 10 mm
Part	Force	Dimension	Stroke	End Fitting
293-020	20 lbs (89N)	19.7" (500mm) - 11.8" (300mm)	7.9" (200mm)	Plastic, 10 mm
293-030	30 lbs (133N)	19.7" (500mm) - 11.8" (300mm)	7.9" (200mm)	Plastic, 10 mm
293-060	60 lbs (267N)	19.7" (500mm) - 11.8" (300mm)	7.9" (200mm)	Plastic, 10 mm
293-100	100 lbs (445N)	19.7" (500mm) - 11.8" (300mm)	7.9" (200mm)	Plastic, 10 mm
Part	Force	Dimension	Stroke	End Fitting
291-050	50 lbs (225N)	20.6" (523mm) - 12.5" (320mm)	8" (203mm)	Steel, 13 mm
291-075	75 lbs (335N)	20.6" (523mm) - 12.5" (320mm)	8" (203mm)	Steel, 13 mm
291-100	100 lbs (445N)	20.6" (523mm) - 12.5" (320mm)	8" (203mm)	Steel, 13 mm
291-150	150 lbs (665N)	20.6" (523mm) - 12.5" (320mm)	8" (203mm)	Steel, 13 mm
291-200	200 lbs (890N)	20.6" (523mm) - 12.5" (320mm)	8" (203mm)	Steel, 13 mm
291-250	250 lbs (1110N)	20.6" (523mm) - 12.5" (320mm)	8" (203mm)	Steel, 13 mm
Part	Force	Dimension	Stroke	End Fitting
295-087	87 lbs (385N)	26.34" (669mm) - 16.10" (409mm)	10.24" (260mm)	Plastic, 10 mm
295-120	120 lbs (534N)	26.34" (669mm) - 16.10" (409mm)	10.24" (260mm)	Plastic, 10 mm
Part	Force	Dimension	Stroke	End Fitting
297-050	50 lbs (225N)	27.875" (710mm) - 16.875" (430mm)	11" (279mm)	Steel, 13 mm
297-075	75 lbs (335N)	27.875" (710mm) - 16.875" (430mm)	11" (279mm)	Steel, 13 mm
297-100	100 lbs (445N)	27.875" (710mm) - 16.875" (430mm)	11" (279mm)	Steel, 13 mm
297-150	150 lbs (665N)	27.875" (710mm) - 16.875" (430mm)	11" (279mm)	Steel, 13 mm
297-200	200 lbs (890N)	27.875" (710mm) - 16.875" (430mm)	11" (279mm)	Steel, 13 mm
297-250	250 lbs (1110N)	27.875" (710mm) - 16.875" (430mm)	11" (279mm)	Steel, 13 mm
Part	Force	Dimension	Stroke	End Fitting
298-056	56 lbs (249N)	35.68" (906mm) - 19.58" (497mm)	16.10" (409mm)	Steel, 13 mm
298-079	79 lbs (351N)	35.68" (906mm) - 19.58" (497mm)	16.10" (409mm)	Steel, 13 mm
298-090	90 lbs (400N)	35.68" (906mm) - 19.58" (497mm)	16.10" (409mm)	Steel, 13 mm
298-203	203 lbs (902N)	35.68" (906mm) - 19.58" (497mm)	16.10" (409mm)	Steel, 13 mm

Telescopic props

Part	Finish	Specifications
261-108	Zinc	8"
261-110	Zinc	10"
261-112	Zinc	12"
261-116	Zinc	16"
261-118	Zinc	18"



261-112

Door Checks

Part	Finish	Specifications
260-101	S/S	11", 15 lbs.
260-151	S/S	13" with 11" arm, 30 lbs.



260-101



260-151

Ball Studs

Part	Finish	Specifications
299-036	Zinc	10 mm
299-017	Zinc	13 mm



299-036



299-017

Brackets

Part	Finish	Specifications
299-101	Zinc	10 mm stud
299-111	Zinc	10 mm stud
299-118	Zinc	10 mm stud, reversible
299-121	Zinc	10 mm stud
299-131	Zinc	10 mm stud
299-141	Zinc	10 mm stud
299-146	S/S	10 mm stud
299-151	Zinc	10 mm stud
299-166	S/S	10 mm stud



299-101



299-111



299-118



299-121



299-131



299-141



299-146



299-151



299-166

End Fittings

Part	Finish	Specifications
299-001	Plastic	10mm receptacle
299-011	Zinc	13mm kit with clip
299-013	Zinc	13mm receptacle
299-015	Zinc	13mm safety clip
299-041	Steel	10mm receptacle



299-001



299-011



299-013



299-015



299-041

General Utility Chain

Hot galvanized of chain reduces W.L.L. by 20%



413-260

Self colored	Galvanized	Zinc	Diameter	Inside diameter	W.L.L.
413-260	413-270	413-280	1/8"	0.25" x 0.69"	325 lbs.
413-261	413-271	413-281	3/16"	0.33" x 0.97"	630 lbs.
413-262	413-272	413-282	1/4"	0.43" x 1.14"	1100 lbs.
413-263	413-273	413-283	5/16"	0.50" x 1.24"	1900 lbs.
413-264	413-274	413-284	3/8"	0.57" x 1.35"	2650 lbs.
413-265	413-275	413-285	1/2"	0.75" x 1.70"	4500 lbs.
413-266	413-276	413-286	5/8"	0.89" x 2.60"	6900 lbs.
413-267	413-277	413-287	3/4"	1.10" x 2.63"	10600 lbs.

Transport Chain

Grade 70



413-291

Yellow Dichromate	Diameter	Inside diameter	W.L.L.
413-291	1/4"	0.50" x 1.00"	3150 lbs.
413-293	5/16"	0.48" x 1.12"	4700 lbs.
413-295	3/8"	0.57" x 1.20"	6600 lbs.
413-299	1/2"	0.75" x 1.70"	11300 lbs.

Clevis Grab Hook

Grade 70



413-201

Part	Chain type	W.L.L.
413-201	1/4"	3150 lbs.
413-203	5/16"	4700 lbs.
413-205	3/8"	6600 lbs.
413-209	1/2"	11300 lbs.

Clevis Slip Hook

Grade 70



413-211



413-221

Without latch	With latch	Chain type	W.L.L.
413-211	413-221	1/4"	2750 lbs.
413-213	413-223	5/16"	4300 lbs.
413-215	413-225	3/8"	5250 lbs.
413-217	413-227	7/16"	6600 lbs.
413-219	413-229	1/2"	9000 lbs.

Eye Slip Tow Hook



413-191



413-193

Part	Eye diameter	Opening	W.L.L.
413-191	5/8"	1/2"	800 lbs.
413-193	3/4"	5/8"	1500 lbs.

Eye slips hook with latch

Alloy

Part	W.L.L.
413-171	1500 lbs.
413-173	2000 lbs.
413-175	3000 lbs.
413-177	4000 lbs.
413-179	6000 lbs.
413-181	9000 lbs.
413-183	14000 lbs.
413-185	22000 lbs.
413-187	30000 lbs.



413-171

Lap links

Zinc

Part	Chain Dia. x I.D.
413-400	3/16" x 1"
413-401	1/4" x 1-1/2"
413-403	5/16" x 1-1/2"
413-405	3/8" x 2"
413-409	1/2" x 2-1/2"



413-400

Quick links

Zinc	Breaking strength	S/S	Breaking strength	Size (inch)	Size (mm)
413-421	200 lbs.	413-435	450 lbs.	1/8"	3 mm
413-423	600 lbs.	413-437	1200 lbs.	3/16"	5 mm
413-425	1000 lbs.	413-439	1400 lbs.	1/4"	6 mm
413-427	1700 lbs.	413-441	2400 lbs.	5/16"	8 mm
413-429	2100 lbs.	413-443	3200 lbs.	3/8"	10 mm
413-431	2600 lbs.	-	-	7/16"	11 mm
413-433	3300 lbs.	413-445	5500 lbs.	1/2"	12 mm



413-421

Screw Pin Anchor Shackles

Galvanized steel

Non rated	Rated	Size	W.L.L.
414-501	414-521	3/16"	660 lbs.
414-503	414-523	1/4"	1000 lbs.
414-505	414-525	5/16"	1500 lbs.
414-507	414-527	3/8"	2000 lbs.
414-509	414-529	7/16"	3000 lbs.
414-511	414-531	1/2"	4000 lbs.
414-513	414-533	5/8"	6500 lbs.
414-515	414-535	3/4"	9500 lbs.
414-517	414-537	7/8"	13000 lbs.
414-519	414-539	1"	17000 lbs.
-	414-541	1-1/8"	19000 lbs.
-	414-543	1-1/4"	24000 lbs.
-	414-545	1-3/8"	27000 lbs.
-	414-547	1-1/2"	34000 lbs.
-	414-549	1-3/4"	50000 lbs.



414-501



418-101



418-111



418-121



418-131



400-109



400-111

Quick Pins

Round, zinc

Part	Specifications
418-101	1/4" x 1-3/8"
418-102	1/4" x 1-3/4"
418-103	5/16" x 1-3/8"
418-104	5/16" x 1-3/4"
418-105	3/8" x 1-3/8"

Quick Pins

Square, zinc

Part	Specifications
418-111	1/4" x 2-1/2"
418-112	5/16" x 2-1/2"
418-113	3/8" x 2-1/4"
418-114	3/8" x 2-1/2"

Lynch Pins

Round, zinc

Part	Specifications
418-121	3/16" x 1-9/16", 1-1/4" usable
418-122	1/4" x 1-9/16", 1-1/4" usable
418-123	5/16" x 1-9/16", 1-1/4" usable
418-124	3/8" x 1-3/4", 1-7/16" usable
418-125	7/16" x 1-9/16", 1-11/32" usable
418-126	7/16" x 1-3/4", 1-1/2" usable

Hitch pins

Zinc

Part	Specifications
418-131	1/2" x 4-1/4"
418-132	5/8" x 4-1/4"
418-134	3/4" x 4-1/4"
418-135	3/4" x 6-1/4"
418-136	7/8" x 6-1/4"
418-137	1" x 6-1/4"
418-138	1-1/8" x 6-1/4"
418-139	1-1/4" x 6-1/4"

Trailer Coupling

SAE Class II

Part	Finish	Specifications
400-109	Zinc	2" x 2-1/2", 3500 lbs
400-111	Zinc	2" x 3", 3500 lbs

Adhesives/sealants Polyurethane

Part	Color	Specifications
575-751	White	75-AM, High performance, 30 un. / box
575-752	Aluminum gray	75-AM, High performance, 30 un. / box
575-753	Black	75-AM, High performance, 30 un. / box
575-754	Colonial White	75-AM, High performance, 30 un. / box
575-758*	Yellow bus	75-AM, High performance, 30 un. / box
575-251	White	25-AM, Fast cure, 36 un. / box
575-252	Aluminum gray	25-AM, Fast cure, 36 un. / box
575-253*	Black	25-AM, Fast cure, 36 un. / box

* Minimum order, 1 box



575-751



575-251

Adhesives/sealants Silicone

Part	Color	Specifications
575-731	White	73-A, Silicone 100%, 24 un. / box
575-732	Aluminum gray	73-A, Silicone 100%, 24 un. / box
575-733	Black	73-A, Silicone 100%, 24 un. / box
575-735	Clear	73-A, Silicone 100%, 24 un. / box



575-731

Adhesives/sealants Neoprene

Part	Color	Specifications
575-651	White	65-A, High capacity, 36 un. / box
575-652	Aluminum gray	65-A, High capacity, 36 un. / box
575-653*	Black	65-A, High capacity, 36 un. / box
580-122	Aluminum gray	65-H, Durable for roof, 4 un. / box

* Minimum order, 1 box



580-122



575-651

Adhesives/sealants Butyl

Part	Color	Specifications
575-501*	White	501-A, General purpose, 36 un. / box
575-502*	Gray	501-A, General purpose, 36 un. / box
575-503	Black	501-A, General purpose, 36 un. / box
590-101*	Aluminum gray	For roofs, 4" x 50', 8 rl. / box
590-106	White	For roofs, 4" x 50', 8 rl. / box
590-201*	Gris	Butyl in rolls, 1/16" x 1/4" x 100', 16 rl. / box
590-206*	Gris	Butyl in rolls, 1/16" x 1/2" x 100', 16 rl. / box
590-211	Gris	Butyl in rolls, 1/16" x 3/4" x 100', 16 rl. / box
590-216	Gris	Butyl in rolls, 1/16" x 1" x 100', 12 rl. / box
590-251*	Gris	Butyl in rolls, 1/8" x 1/2" x 60', 20 rl. / box
590-256	Gris	Butyl in rolls, 1/8" x 5/8" x 65', 16 rl. / box
590-261*	Gris	Butyl in rolls, 1/8" x 3/4" x 60', 16 rl. / box
590-266*	Gris	Butyl in rolls, 1/8" x 1" x 65', 16 rl. / box
590-361	Black	Butyl in rolls, 1/8" x 3/4" x 60', 16 rl. / box

* Minimum order, 1 box



575-501



590-101



590-201

Rubber Fenders Edge Trims

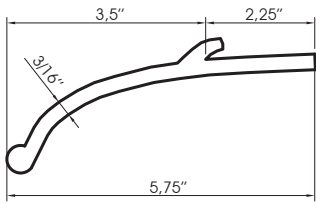

653-101

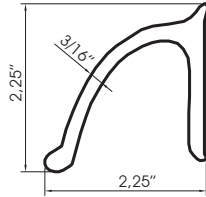

653-111

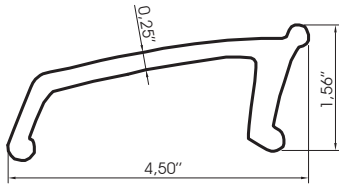

653-121

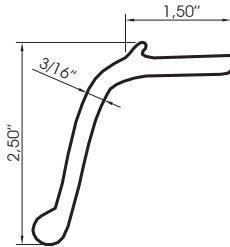

653-141

Rubber fenders

Part	Specifications
653-101	52 feet - 1/4" thick
653-111	100 feet - 3/16" thick
653-121	50 feet - 1/4" thick
653-141	100 feet - 3/16" thick

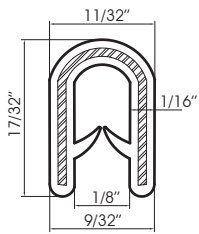

652-601

Edge trim

Part	Specifications
652-601	Double lips, 1/8"

- More models available, visit www.jimexs.com

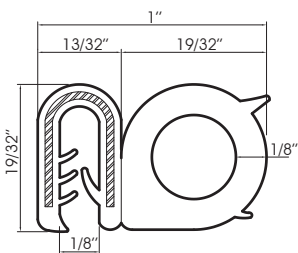

652-101

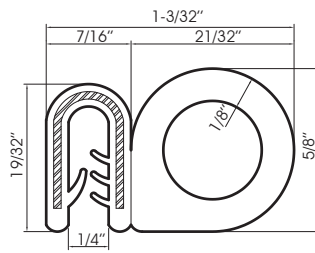

652-201

Edge trims with bulb

Part	Specifications
652-101	Bulb on side, 1/8"
652-201	Bulb on side, 1/4"
652-806	Bulb on top, 1/8"
652-811	Bulb on top (small), 1/8"

- More models available, visit www.jimexs.com

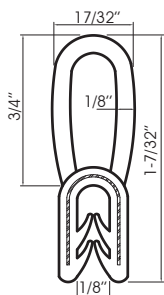

652-806

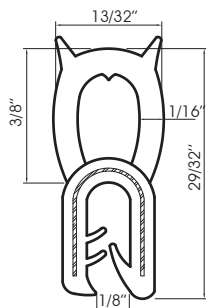

652-811

Weatherstrips

Part	Width	Length	Rolls / box	Thickness
675-111	1/2"	100'	24	1/16"
675-126	1"	100'	12	1/16"

Part	Width	Length	Rolls / box	Thickness
675-206	3/8"	50'	32	1/8"
675-211	1/2"	50'	24	1/8"
675-221	3/4"	50'	16	1/8"
675-226	1"	50'	12	1/8"
675-236	1-1/2"	50'	8	1/8"
675-241	2"	50'	6	1/8"

Part	Width	Length	Rolls / box	Thickness
675-306	3/8"	50'	32	3/16"
675-311	1/2"	50'	24	3/16"
675-321	3/4"	50'	16	3/16"
675-326	1"	50'	12	3/16"
675-336	1-1/2"	50'	8	3/16"

Part	Width	Length	Rolls / box	Thickness
675-406	3/8"	37,5'	32	1/4"
675-411	1/2"	37,5'	24	1/4"
675-421	3/4"	37,5'	16	1/4"
675-426	1"	37,5'	12	1/4"
675-436	1-1/2"	37,5'	8	1/4"
675-441	2"	37,5'	6	1/4"
675-451	3"	37,5'	4	1/4"

Part	Width	Length	Rolls / box	Thickness
675-521	3/4"	30'	16	5/16"
675-526	1"	30'	12	5/16"
675-536	1-1/2"	30'	8	5/16"

Part	Width	Length	Rolls / box	Thickness
675-611	1/2"	25'	24	3/8"
675-621	3/4"	25'	16	3/8"
675-626	1"	25'	12	3/8"
675-641	2"	25'	6	3/8"

Part	Width	Length	Rolls / box	Thickness
675-711	1/2"	25'	24	1/2"
675-726	1"	25'	16	1/2"
675-736	1-1/2"	25'	12	1/2"

Part	Width	Length	Rolls / box	Thickness
675-821	3/4"	12,5'	16	5/8"

Part	Width	Length	Rolls / box	Thickness
675-911	1/2"	12,5'	24	3/4"
675-921	3/4"	12,5'	16	3/4"
675-926	1"	12,5'	12	3/4"
675-936	1-1/2"	12,5'	8	3/4"



675-XXX Series
1 adhesive side, closed cell

Rubber bumpers



Part	Lenght	Width	Height	Holes Diameter	Center - Center
610-053	4-3/4"	3-1/16"	3-3/4"	1/2"	2-1/2"
610-127	6"	2-3/4"	3-1/4"	1/2"	2-1/2"
610-102	6"	4"	3-3/8"	1/2"	2-1/2"
610-046	7-3/4"	3"	3-1/4"	1/2"	3-5/16"
611-151	7-5/8"	2-1/4"	2"	3/8"	4-3/4"
610-007	7-7/8"	2-5/8"	2-1/4"	3/8"	4-1/2"
612-111	8-1/16"	5-1/2"	3-1/2"	1/2"	5-1/2"
610-092	8-3/8"	1-15/16"	1-15/16"	5-11/32"	5"
610-014	16"	2"	2"	3/8"	6-1/2"



Bumper stoppers

Part	External Diameter	Height	Hole	Specifications
607-101	1"	13/16"	1/8"	-
607-111	1"	1"	5/32"	-
607-341	2-1/2"	1"	3/8"	-
607-351	1-1/4"	1-7/8"	3/8"	-



Série 625

Extrusions

Part	Lenght	Width	Height	Specifications
625-008	8"	4-1/2"	3-3/4"	-
625-012	12"	4-1/2"	3-3/4"	-
625-022	22"	4-1/2"	3-3/4"	-
625-096	96"	4-1/2"	3-3/4"	-
625-106	6"	4"	3-7/8"	2 holes 5/8", 3-1/8" C.-C.



Wheel Chocks

Part	Lenght	Width	Height	Specifications
612-131	8-1/2"	7-5/8"	5-5/8"	Rubber
612-141	9-1/2"	6-1/4"	7-1/4"	Rubber
612-161	9-1/4"	3-7/8"	3-3/4"	Rubber
612-501	8"	8-1/2"	15-1/4"	Aluminum
612-521	7-3/4"	8-1/2"	12"	Aluminum
612-541	7"	6-3/16"	12-1/8"	Aluminum
612-551	-	-	-	Holder for 612-501

Mud flaps

Part	Thickness	Width	Height
626-124	1/4"	24"	24"
626-130	1/4"	24"	30"
626-136	1/4"	24"	36"



626-124

Mud flap holders

Part	Finish	Specifications
626-001	Zinc	for 24" mud flap
626-003	Chrome	for 24" mud flap

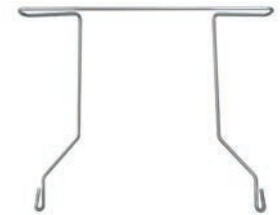

626-00X

Floor mattings

Sold per yard (3 feet), 25 yards roll

Part	Thickness	Width	Grooves
680-501	1/8"	36"	Wide
680-506	1/8"	36"	Narrow
680-511	1/8"	48"	Wide
680-516	1/8"	48"	Narrow
680-521	1/4"	36"	Wide



Rainure large



Rainure étroite

Interlocking PVC Tiles

Part	Height	Width	Thickness
680-301	12"	12"	3/4"
680-331	12"	12"	9/16"

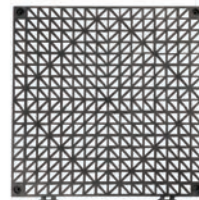

680-301

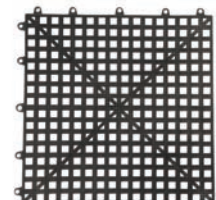

680-331

Anti-skid tapes with adhesive

Part	Width	Length	Adhesive
940-101	1"	60'	Ultra-resistant acrylic
940-102	2"	60'	Ultra-resistant acrylic
940-104	4"	60'	Ultra-resistant acrylic
940-106	6"	60'	Ultra-resistant acrylic
940-112	12"	60'	Ultra-resistant acrylic

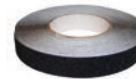

940-101



940-106



940-112



901-151



901-161



901-201

Folding steps

Part	Finish	Specifications
901-151	Zingué	6-1/2" wide, 4" C.-C. holes
901-161	Galvanized	6-1/2" wide, 4" C.-C. holes
901-201	Aluminum	6-3/4" x 8-1/2", Chrome finish

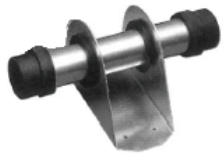

707-101



707-121



707-151

Document holders

Part	Finish	Specifications
707-101	Aluminum	9" x 1-5/8" (tube), 5-3/4" x 4"
707-121	Aluminum	6" diameter
707-151	Plastic	8-1/2"W x 13-1/2"H x 1-1/2"D



905-101, 905-121



905-103, 905-123



905-106, 905-126



905-151

Roll-up door rollers

2-1/2" Size	6" Size	Finish
905-101	905-121	Yellow Zinc
905-103	905-123	Zinc
905-106	905-126	Nylon
905-151	-	Steel



905-3XX



905-2XX

Roll-up door cables

Galvanized	Stainless Steel	Length
905-210	905-310	110"
905-215	905-315	115"
905-220	905-320	120"
905-225	905-325	125"
905-230	905-330	130"

Placard holders

Part	Finish	Specifications
801-001	Aluminum	S/S offset clip - Regular
801-003	Aluminum	S/S offset clip - "Split"
801-021	White Alu.	S/S offset clip - Regular
801-023	White Alu.	S/S offset clip - "Split"
801-731	S/S	Offset clip only

Receptacle for neck fuel tank

Part	Finish	Specifications
707-201	S/S	6-3/16", 2-1/4"

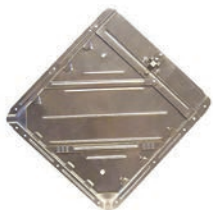

801-001



801-003



707-201

Louvered vents

Part	Finish	Specifications
801-901	Aluminum	with shutter
801-906	Aluminum	without shutter
801-951	Aluminum	with screen, 1"
801-952	Aluminum	with screen, 1-1/2"
801-953	Aluminum	with screen, 2"
801-954	Aluminum	with screen, 2-1/2"
801-955	Aluminum	with screen, 3"
801-956	Aluminum	with screen, 4"
801-957	Aluminum	with screen, 6"



801-95X



801-90X

Flettner Ventilators

Part	Finish	Specifications
750-001	Plastic	Flettner TCX-2 - black
750-006	Plastic	Flettner TCX-2 - narrow base - black
750-021	Plastic	Flettner TCX-2 - white
750-041	Plastic	Adaptor for Flettner TCX
750-101	Plastic	Flettner 2000 - black
750-141	Plastic	Adaptor for Flettner 2000



750-001



750-101

Air vents

Part	Finish	Specifications
752-101	Aluminum	Finish trim - plastic
752-201	Aluminum	Low profile
752-211	Aluminum	Black plastic handle



752-101

Heaters 12V

Part	Length	Width	Height	Specifications
805-462	8.25"	8.16"	8.60"	5.8A, 21 000 BTU, bottom connection
805-504	19.17"	7.50"	8.25"	11.6A, 42 000 BTU, rear connection
805-529	19.17"	7.50"	8.25"	11.6A, 42 000 BTU, bottom connection



805-462



805-504



805-529

Aluminum 5056 blind rivets

Steel mandrel, open end

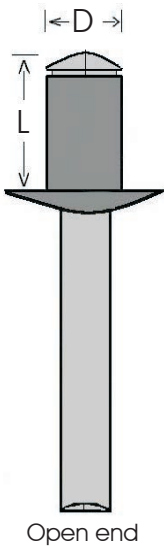

Part	D	Grip Range	L
501-602	3/16" (4.8 mm)	0.020" - 0.125" (0.5mm - 3.2mm)	0.476" (12.1 mm)
501-603	3/16" (4.8 mm)	0.126" - 0.189" (3.2mm - 4.8mm)	0.539" (13.7 mm)
501-604	3/16" (4.8 mm)	0.190" - 0.250" (4.8mm - 6.4mm)	0.598" (15.2 mm)
501-606	3/16" (4.8 mm)	0.251" - 0.375" (6.4mm - 9.5mm)	0.724" (18.4 mm)
501-608	3/16" (4.8 mm)	0.376" - 0.500" (9.5mm - 12.7mm)	0.850" (21.6 mm)
501-610	3/16" (4.8 mm)	0.501" - 0.625" (12.7mm - 15.9mm)	0.976" (24.8 mm)
501-612	3/16" (4.8 mm)	0.626" - 0.750" (15.9mm - 19.1mm)	1.098" (27.9 mm)
501-614	3/16" (4.8 mm)	0.751" - 0.875" (19.1mm - 22.2mm)	1.228" (31.2 mm)
501-616	3/16" (4.8 mm)	0.876" - 1.000" (22.2mm - 25.4mm)	1.350" (34.3 mm)
501-618	3/16" (4.8 mm)	1.000" - 1.125" (25.4mm - 28.6mm)	1.476" (37.5 mm)
501-802	1/4" (6.4 mm)	0.020" - 0.125" (0.5mm - 3.2mm)	0.571" (14.5 mm)
501-804	1/4" (6.4 mm)	0.126" - 0.250" (3.2mm - 6.4mm)	0.728" (18.5 mm)
501-806	1/4" (6.4 mm)	0.251" - 0.375" (6.4mm - 9.5mm)	0.854" (21.7 mm)
501-808	1/4" (6.4 mm)	0.376" - 0.500" (9.5mm - 12.7mm)	0.980" (24.9 mm)
501-810	1/4" (6.4 mm)	0.501" - 0.625" (12.7mm - 15.9mm)	1.102" (28.0 mm)
501-812	1/4" (6.4 mm)	0.626" - 0.750" (15.9mm - 19.1mm)	1.228" (31.2 mm)
501-814	1/4" (6.4 mm)	0.751" - 0.875" (19.1mm - 22.2mm)	1.354" (34.4 mm)
501-816	1/4" (6.4 mm)	0.876" - 1.000" (22.2mm - 25.4mm)	1.480" (37.6 mm)

Aluminum 5056 blind rivets

Steel mandrel, large open end

Part	D	Grip Range	L
505-603	3/16" (3.2 mm)	0.126" - 0.125" (3.2mm - 4.8mm)	0.539" (13.7 mm)
505-604	3/16" (3.2 mm)	0.190" - 0.250" (4.8mm - 6.4mm)	0.598" (15.2 mm)
505-606	3/16" (3.2 mm)	0.251" - 0.375" (6.4mm - 9.5mm)	0.724" (18.4 mm)
505-608	3/16" (3.2 mm)	0.376" - 0.500" (9.5mm - 12.7mm)	0.850" (21.6 mm)
505-610	3/16" (3.2 mm)	0.501" - 0.625" (12.7mm - 15.9mm)	0.976" (24.8 mm)
505-612	3/16" (3.2 mm)	0.626" - 0.750" (15.9mm - 19.1mm)	1.098" (27.9 mm)
505-614	3/16" (3.2 mm)	0.751" - 0.875" (19.1mm - 22.2mm)	1.228" (31.2 mm)
505-616	3/16" (3.2 mm)	0.876" - 1.000" (22.2mm - 25.4mm)	1.350" (34.3 mm)
505-618	3/16" (3.2 mm)	1.000" - 1.125" (25.4mm - 28.6mm)	1.476" (37.5 mm)

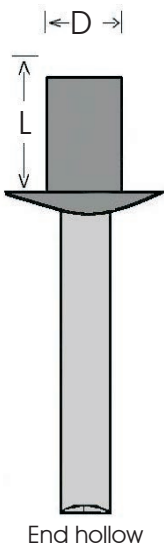

Aluminum 5056 blind rivets

Steel mandrel, end hollow

Part	D	Grip Range	L
506-602	3/16" (4.8 mm)	0.062" - 0.125" (1.6mm - 3.2mm)	0.346" (8.8 mm)
506-603	3/16" (4.8 mm)	0.126" - 0.189" (3.2mm - 4.8mm)	0.465" (11.8 mm)
506-604	3/16" (4.8 mm)	0.190" - 0.250" (4.8mm - 6.4mm)	0.531" (13.5 mm)
506-606	3/16" (4.8 mm)	0.251" - 0.375" (6.4mm - 9.5mm)	0.602" (15.3 mm)
506-608	3/16" (4.8 mm)	0.376" - 0.500" (9.5mm - 12.7mm)	0.720" (18.3 mm)
506-610	3/16" (4.8 mm)	0.501" - 0.625" (12.7mm - 15.9mm)	0.839" (21.3 mm)
506-612	3/16" (4.8 mm)	0.626" - 0.750" (15.9mm - 19.1mm)	0.976" (24.8 mm)
506-802	1/4" (6.4 mm)	0.062" - 0.125" (1.6mm - 3.2mm)	0.406" (10.3 mm)
506-804	1/4" (6.4 mm)	0.126" - 0.250" (3.2mm - 6.4mm)	0.531" (13.5 mm)
506-806	1/4" (6.4 mm)	0.251" - 0.375" (6.4mm - 9.5mm)	0.661" (16.8 mm)
506-808	1/4" (6.4 mm)	0.376" - 0.500" (9.5mm - 12.7mm)	0.780" (19.8 mm)
506-810	1/4" (6.4 mm)	0.501" - 0.625" (12.7mm - 15.9mm)	0.917" (23.3 mm)

Aluminum 5052 blind rivets

Aluminum alloy mandrel, open end

Part	D	Grip Range	L
511-602	3/16" (4.8 mm)	0.020" - 0.125" (0.5mm - 3.2mm)	0.476" (12.1 mm)
511-603	3/16" (4.8 mm)	0.126" - 0.189" (3.2mm - 4.8mm)	0.539" (13.7 mm)
511-604	3/16" (4.8 mm)	0.190" - 0.250" (4.8mm - 6.4mm)	0.598" (15.2 mm)
511-606	3/16" (4.8 mm)	0.251" - 0.375" (6.4mm - 9.5mm)	0.724" (18.4 mm)
511-608	3/16" (4.8 mm)	0.376" - 0.500" (9.5mm - 12.7mm)	0.850" (21.6 mm)
511-610	3/16" (4.8 mm)	0.501" - 0.625" (12.7mm - 15.9mm)	0.976" (24.8 mm)
511-612	3/16" (4.8 mm)	0.626" - 0.750" (15.9mm - 19.1mm)	1.098" (27.9 mm)
511-614	3/16" (4.8 mm)	0.751" - 0.875" (19.1mm - 22.2mm)	1.228" (31.2 mm)
511-616	3/16" (4.8 mm)	0.876" - 1.000" (22.2mm - 25.4mm)	1.350" (34.3 mm)
511-618	3/16" (4.8 mm)	1.000" - 1.125" (25.4mm - 28.6mm)	1.476" (37.5 mm)
511-802	1/4" (6.4 mm)	0.020" - 0.125" (0.5mm - 3.2mm)	0.571" (14.5 mm)
511-804	1/4" (6.4 mm)	0.126" - 0.250" (3.2mm - 6.4mm)	0.728" (18.5 mm)
511-806	1/4" (6.4 mm)	0.251" - 0.375" (6.4mm - 9.5mm)	0.854" (21.7 mm)
511-808	1/4" (6.4 mm)	0.376" - 0.500" (9.5mm - 12.7mm)	0.980" (24.9 mm)
511-810	1/4" (6.4 mm)	0.501" - 0.625" (12.7mm - 15.9mm)	1.102" (28.0 mm)
511-812	1/4" (6.4 mm)	0.626" - 0.750" (15.9mm - 19.1mm)	1.228" (31.2 mm)
511-814	1/4" (6.4 mm)	0.751" - 0.875" (19.1mm - 22.2mm)	1.354" (34.4 mm)
511-816	1/4" (6.4 mm)	0.876" - 1.000" (22.2mm - 25.4mm)	1.480" (37.6 mm)

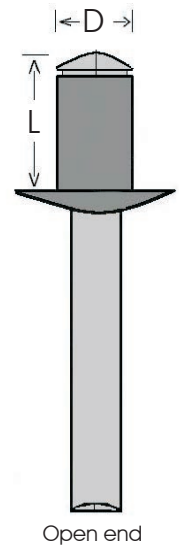

Aluminum 5052 blind rivets

Aluminum alloy mandrel, large open end

Part	D	Grip Range	L
515-603	3/16" (3.2 mm)	0.126" - 0.125" (3.2mm - 4.8mm)	0.539" (13.7 mm)
515-604	3/16" (3.2 mm)	0.190" - 0.250" (4.8mm - 6.4mm)	0.598" (15.2 mm)
515-606	3/16" (3.2 mm)	0.251" - 0.375" (6.4mm - 9.5mm)	0.724" (18.4 mm)
515-608	3/16" (3.2 mm)	0.376" - 0.500" (9.5mm - 12.7mm)	0.850" (21.6 mm)
515-610	3/16" (3.2 mm)	0.501" - 0.625" (12.7mm - 15.9mm)	0.976" (24.8 mm)
515-612	3/16" (3.2 mm)	0.626" - 0.750" (15.9mm - 19.1mm)	1.098" (27.9 mm)
515-614	3/16" (3.2 mm)	0.751" - 0.875" (19.1mm - 22.2mm)	1.228" (31.2 mm)
515-616	3/16" (3.2 mm)	0.876" - 1.000" (22.2mm - 25.4mm)	1.350" (34.3 mm)
515-618	3/16" (3.2 mm)	1.000" - 1.125" (25.4mm - 28.6mm)	1.476" (37.5 mm)

Stainless steel blind rivets

Carbon steel mandrel, open end

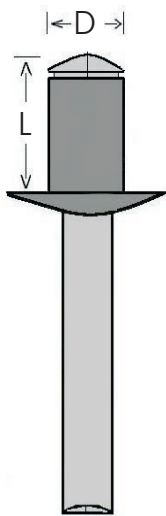

Bout ouvert

Part	D	Grip Range	L
521-602	3/16" (4.8 mm)	0.020" - 0.125" (0.5mm - 3.2mm)	0.476" (12.1 mm)
521-603	3/16" (4.8 mm)	0.126" - 0.189" (3.2mm - 4.8mm)	0.539" (13.7 mm)
521-604	3/16" (4.8 mm)	0.190" - 0.250" (4.8mm - 6.4mm)	0.598" (15.2 mm)
521-606	3/16" (4.8 mm)	0.251" - 0.375" (6.4mm - 9.5mm)	0.724" (18.4 mm)
521-608	3/16" (4.8 mm)	0.376" - 0.500" (9.5mm - 12.7mm)	0.850" (21.6 mm)
521-610	3/16" (4.8 mm)	0.501" - 0.625" (12.7mm - 15.9mm)	0.976" (24.8 mm)
521-612	3/16" (4.8 mm)	0.626" - 0.750" (15.9mm - 19.1mm)	1.098" (27.9 mm)
521-614	3/16" (4.8 mm)	0.751" - 0.875" (19.1mm - 22.2mm)	1.228" (31.2 mm)
521-802	1/4" (6.4 mm)	0.020" - 0.125" (0.5mm - 3.2mm)	0.571" (14.5 mm)
521-804	1/4" (6.4 mm)	0.126" - 0.250" (3.2mm - 6.4mm)	0.728" (18.5 mm)
521-806	1/4" (6.4 mm)	0.251" - 0.375" (6.4mm - 9.5mm)	0.854" (21.7 mm)
521-808	1/4" (6.4 mm)	0.376" - 0.500" (9.5mm - 12.7mm)	0.980" (24.9 mm)
521-810	1/4" (6.4 mm)	0.501" - 0.625" (12.7mm - 15.9mm)	1.102" (28.0 mm)

Stainless steel blind rivets

S/S mandrel, open end

Part	D	Grip Range	L
531-602	3/16" (4.8 mm)	0.020" - 0.125" (0.5mm - 3.2mm)	0.476" (12.1 mm)
531-603	3/16" (4.8 mm)	0.126" - 0.189" (3.2mm - 4.8mm)	0.539" (13.7 mm)
531-604	3/16" (4.8 mm)	0.190" - 0.250" (4.8mm - 6.4mm)	0.598" (15.2 mm)
531-606	3/16" (4.8 mm)	0.251" - 0.375" (6.4mm - 9.5mm)	0.724" (18.4 mm)
531-608	3/16" (4.8 mm)	0.376" - 0.500" (9.5mm - 12.7mm)	0.850" (21.6 mm)
531-610	3/16" (4.8 mm)	0.501" - 0.625" (12.7mm - 15.9mm)	0.976" (24.8 mm)
531-612	3/16" (4.8 mm)	0.626" - 0.750" (15.9mm - 19.1mm)	1.098" (27.9 mm)
531-614	3/16" (4.8 mm)	0.751" - 0.875" (19.1mm - 22.2mm)	1.228" (31.2 mm)
531-802	1/4" (6.4 mm)	0.020" - 0.125" (0.5mm - 3.2mm)	0.571" (14.5 mm)
531-804	1/4" (6.4 mm)	0.126" - 0.250" (3.2mm - 6.4mm)	0.728" (18.5 mm)
531-806	1/4" (6.4 mm)	0.251" - 0.375" (6.4mm - 9.5mm)	0.854" (21.7 mm)
531-808	1/4" (6.4 mm)	0.376" - 0.500" (9.5mm - 12.7mm)	0.980" (24.9 mm)
531-810	1/4" (6.4 mm)	0.501" - 0.625" (12.7mm - 15.9mm)	1.102" (28.0 mm)

Carbon steel blind rivets

Carbon steel mandrel, open end

Part	D	Grip Range	L
541-602	3/16" (4.8 mm)	0.020" - 0.125" (0.5mm - 3.2mm)	0.476" (12.1 mm)
541-603	3/16" (4.8 mm)	0.126" - 0.189" (3.2mm - 4.8mm)	0.539" (13.7 mm)
541-604	3/16" (4.8 mm)	0.190" - 0.250" (4.8mm - 6.4mm)	0.598" (15.2 mm)
541-606	3/16" (4.8 mm)	0.251" - 0.375" (6.4mm - 9.5mm)	0.724" (18.4 mm)
541-608	3/16" (4.8 mm)	0.376" - 0.500" (9.5mm - 12.7mm)	0.850" (21.6 mm)
541-610	3/16" (4.8 mm)	0.501" - 0.625" (12.7mm - 15.9mm)	0.976" (24.8 mm)
541-612	3/16" (4.8 mm)	0.626" - 0.750" (15.9mm - 19.1mm)	1.098" (27.9 mm)
541-614	3/16" (4.8 mm)	0.751" - 0.875" (19.1mm - 22.2mm)	1.228" (31.2 mm)
541-616	3/16" (4.8 mm)	0.876" - 1.000" (22.2mm - 25.4mm)	1.350" (34.3 mm)
541-618	3/16" (4.8 mm)	1.000" - 1.125" (25.4mm - 28.6mm)	1.476" (37.5 mm)
541-802	1/4" (6.4 mm)	0.020" - 0.125" (0.5mm - 3.2mm)	0.571" (14.5 mm)
541-804	1/4" (6.4 mm)	0.126" - 0.250" (3.2mm - 6.4mm)	0.728" (18.5 mm)
541-806	1/4" (6.4 mm)	0.251" - 0.375" (6.4mm - 9.5mm)	0.854" (21.7 mm)
541-808	1/4" (6.4 mm)	0.376" - 0.500" (9.5mm - 12.7mm)	0.980" (24.9 mm)
541-810	1/4" (6.4 mm)	0.501" - 0.625" (12.7mm - 15.9mm)	1.102" (28.0 mm)
541-812	1/4" (6.4 mm)	0.626" - 0.750" (15.9mm - 19.1mm)	1.228" (31.2 mm)
541-814	1/4" (6.4 mm)	0.751" - 0.875" (19.1mm - 22.2mm)	1.354" (34.4 mm)
541-816	1/4" (6.4 mm)	0.876" - 1.000" (22.2mm - 25.4mm)	1.480" (37.6 mm)

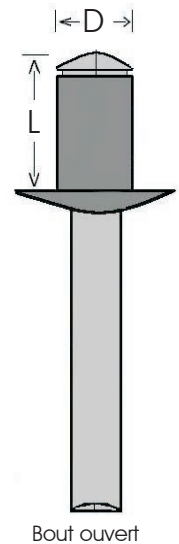

Carbon steel blind rivets

Carbon steel mandrel, large open end

Part	D	Grip Range	L
545-603	3/16" (3.2 mm)	0.126" - 0.125" (3.2mm - 4.8mm)	0.539" (13.7 mm)
545-604	3/16" (3.2 mm)	0.190" - 0.250" (4.8mm - 6.4mm)	0.598" (15.2 mm)
545-606	3/16" (3.2 mm)	0.251" - 0.375" (6.4mm - 9.5mm)	0.724" (18.4 mm)
545-608	3/16" (3.2 mm)	0.376" - 0.500" (9.5mm - 12.7mm)	0.850" (21.6 mm)
545-610	3/16" (3.2 mm)	0.501" - 0.625" (12.7mm - 15.9mm)	0.976" (24.8 mm)
545-612	3/16" (3.2 mm)	0.626" - 0.750" (15.9mm - 19.1mm)	1.098" (27.9 mm)
545-614	3/16" (3.2 mm)	0.751" - 0.875" (19.1mm - 22.2mm)	1.228" (31.2 mm)
545-616	3/16" (3.2 mm)	0.876" - 1.000" (22.2mm - 25.4mm)	1.350" (34.3 mm)
545-618	3/16" (3.2 mm)	1.000" - 1.125" (25.4mm - 28.6mm)	1.476" (37.5 mm)



551-604

Rivets

Part	Diameter	Grip Range	Material
551-604	3/16" (4.8 mm)	0.062"-0.270" (1.6mm - 6.9mm)	Steel
551-607	3/16" (4.8 mm)	0.214"-0.437" (5.4mm - 11.1mm)	Steel
551-806	1/4" (6.4 mm)	0.080"-0.375" (2.0mm - 9.5mm)	Steel
551-810	1/4" (6.4 mm)	0.350"-0.625" (8.9mm - 15.9mm)	Steel

Part	Diameter	Grip Range	Material
552-604	3/16" (4.8 mm)	0.062"-0.270" (1.6mm - 6.9mm)	Aluminum
552-607	3/16" (4.8 mm)	0.214"-0.437" (5.4mm - 11.1mm)	Aluminum
552-806	1/4" (6.4 mm)	0.080"-0.375" (2.0mm - 9.5mm)	Aluminum
552-810	1/4" (6.4 mm)	0.350"-0.625" (8.9mm - 15.9mm)	Aluminum

Part	Diameter	Grip Range	Material
553-604	3/16" (4.8 mm)	0.062"-0.270" (1.6mm - 6.9mm)	S/S
553-607	3/16" (4.8 mm)	0.214"-0.437" (5.4mm - 11.1mm)	S/S
553-806	1/4" (6.4 mm)	0.080"-0.375" (2.0mm - 9.5mm)	S/S
553-810	1/4" (6.4 mm)	0.350"-0.625" (8.9mm - 15.9mm)	S/S



555-101

Threaded inserts

Part	Thread	Grip Range	Material
555-101	1/4-20 UNC	0.027"-0.165" (0.7mm - 4.2mm)	Steel
555-106	1/4-20 UNC	0.165"-0.260" (4.2mm - 6.6mm)	Steel
555-111	5/16-18 UNC	0.027"-0.150" (0.7mm - 3.8mm)	Steel
555-116	5/16-18 UNC	0.150"-0.312" (3.8mm - 7.9mm)	Steel
555-121	3/8-16 UNC	0.027"-0.150" (0.7mm - 3.8mm)	Steel

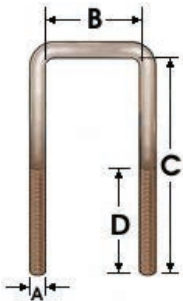

Threaded U-bolts

Part	A	B	C	D
906-010	5/8"	3-1/2"	10"	6"
906-012	5/8"	3-1/2"	12"	6"
906-014	5/8"	3-1/2"	14"	6"
906-016	5/8"	3-1/2"	16"	6"
906-018	5/8"	3-1/2"	18"	6"
906-020	5/8"	3-1/2"	20"	6"
906-022	5/8"	3-1/2"	22"	6"



Threaded straight rods

Part	A	Length	D
906-185	5/8"	18-1/2"	3-1/2"
906-205	5/8"	20-1/2"	3-1/2"
906-225	5/8"	22-1/2"	3-1/2"
906-245	5/8"	24-1/2"	3-1/2"
906-265	5/8"	26-1/2"	3-1/2"
906-285	5/8"	28-1/2"	3-1/2"
906-305	5/8"	30-1/2"	3-1/2"
906-325	5/8"	32-1/2"	3-1/2"
906-345	5/8"	34-1/2"	3-1/2"
906-365	5/8"	36-1/2"	3-1/2"
906-385	5/8"	38-1/2"	3-1/2"
906-405	5/8"	40-1/2"	3-1/2"
906-425	5/8"	42-1/2"	3-1/2"
906-445	5/8"	44-1/2"	3-1/2"
906-465	5/8"	46-1/2"	3-1/2"



906-000

Tie plate

Part	Specifications
906-000	6" x 1-1/2" x 1/2"



Parts Index

Part	Page	Part	Page	Part	Page	Part	Page	Part	Page	Part	Page
118-124	1	202-255	17	213-205	14	220-509	13	222-804	10	224-926	6
118-136	1	202-257	17	213-301	14	220-801	12	222-805	10	225-101	2
118-148	1	202-261	17	213-303	14	220-806	12	222-806	10	225-102	2
118-160	1	202-265	17	215-101	15	220-821	12	222-807	10	225-103	2
118-236	1	202-301	17	215-104	15	220-901	13	222-808	10	225-191	2
118-248	1	202-601	18	215-109	15	220-905	13	222-809	10	225-201	2
118-260	1	203-001	14	215-112	15	220-911	13	222-810	10	225-202	2
118-436	1	203-201	14	215-117	15	221-101	11	222-930	9	225-203	2
118-448	1	203-251	14	215-120	15	221-106	11	222-931	9	225-291	2
118-460	1	203-261	14	215-125	15	221-186	11	222-932	9	225-301	5
118-536	1	203-271	14	215-128	15	221-196	11	222-935	9	225-401	3
118-548	1	203-283	14	215-133	15	221-201	11	222-936	9	225-491	3
118-560	1	203-701	14	215-136	15	221-203	11	222-937	9	225-501	3
124-124	1	203-706	14	215-141	15	221-211	11	222-940	9	225-502	3
124-136	1	203-801	20	215-217	15	221-301	11	222-941	9	225-503	3
124-148	1	203-806	20	215-220	15	221-311	11	222-942	9	225-521	3
124-160	1	203-821	20	215-225	15	221-521	12	222-945	9	225-522	3
124-172	1	204-108	18	215-228	15	221-708	11	222-946	9	225-523	3
124-236	1	204-112	18	215-233	15	221-851	11	222-947	9	225-591	3
124-248	1	204-116	18	215-236	15	221-901	12	222-951	9	225-596	3
124-260	1	204-308	18	215-241	15	221-911	12	222-952	9	225-701	5
124-272	1	204-312	18	216-101	15	222-051	10	222-953	9	225-791	5
128-012	1	204-316	18	216-104	15	222-111	9	222-954	9	225-819	5
128-018	1	204-404	18	216-109	15	222-115	9	222-955	9	225-851	5
128-024	1	204-412	18	216-112	15	222-121	9	222-956	9	225-853	5
130-136	1	204-418	18	216-117	15	222-123	9	222-957	9	225-855	5
130-148	1	204-508	17	216-120	15	222-125	9	222-985	10	225-951	2
130-160	1	204-728	18	216-125	15	222-201	10	222-987	10	225-951	3
130-172	1	204-801	17	216-128	15	222-203	10	223-001	8	225-955	3
130-236	1	204-806	17	216-133	15	222-205	10	223-101	13	225-961	2
130-248	1	204-821	17	216-136	15	222-207	10	223-103	13	225-965	2
130-260	1	204-826	17	216-141	15	222-209	10	223-105	13	226-001	4
130-272	1	204-841	17	216-217	15	222-211	10	223-111	13	226-002	4
136-124	1	204-846	17	216-220	15	222-213	10	223-121	13	226-003	4
136-136	1	204-901	18	216-225	15	222-215	10	223-201	13	226-101	4
136-148	1	210-105	14	216-228	15	222-217	10	223-203	13	226-102	4
136-160	1	210-111	14	216-233	15	222-219	10	223-205	13	226-103	4
136-172	1	210-201	14	216-236	15	222-221	10	223-207	13	226-191	4
136-236	1	210-203	14	216-241	15	222-223	10	223-221	13	226-195	4
136-248	1	210-205	14	218-109	15	222-225	10	223-351	8	226-199	4
136-260	1	210-207	14	218-117	15	222-227	10	224-401	8	226-406	4
136-272	1	210-301	14	218-120	15	222-451	10	224-406	8	226-451	4
202-120	17	210-303	14	218-125	15	222-581	9	224-411	8	226-452	4
202-201	8	210-501	14	218-133	15	222-583	10	224-416	8	226-453	4
202-211	17	212-101	14	218-136	15	222-585	10	224-457	5	226-751	6
202-216	18	212-201	14	218-141	15	222-589	9	224-481	8	226-771	6
202-221	17	212-303	14	218-217	15	222-621	7	224-491	8	227-216	4
202-231	17	213-101	14	218-220	15	222-641	7	224-601	8	227-221	4
202-241	17	213-103	14	220-501	13	222-801	10	224-606	8	227-226	4
202-251	17	213-105	14	220-503	13	222-802	10	224-801	6	227-236	4
202-253	17	213-201	14	220-507	13	222-803	10	224-921	6	227-241	4



Part	Page	Part	Page	Part	Page	Part	Page	Part	Page	Part	Page
227-246	4	235-702	3	251-141	22	289-060	23	323-210	21	323-636	21
227-951	4	235-703	3	251-145	22	289-090	23	323-212	21	323-648	21
227-957	4	235-704	3	251-148	22	289-120	23	323-214	21	400-101	27
228-201	8	235-705	3	251-151	22	291-050	23	323-216	21	400-109	27
228-206	8	237-101	2	251-161	22	291-075	23	323-218	21	410-021	19
228-421	7	237-111	2	251-171	22	291-100	23	323-220	21	410-091	19
228-423	7	237-121	2	251-181	22	291-150	23	323-222	21	410-101	19
228-425	7	237-131	2	251-201	22	291-200	23	323-224	21	410-106	19
228-431	7	240-101	19	251-206	22	291-250	23	323-310	21	410-111	19
228-441	7	240-103	19	251-211	22	293-020	23	323-312	21	410-121	19
228-451	7	240-106	19	251-216	22	293-030	23	323-314	21	410-131	19
228-461	7	240-111	19	251-221	22	293-060	23	323-316	21	410-201	19
228-481	7	240-121	19	251-226	22	293-100	23	323-318	21	410-203	19
228-483	7	240-151	19	251-231	22	295-087	23	323-320	21	410-205	19
228-491	7	240-201	20	251-236	22	295-120	23	323-322	21	410-207	19
229-106	12	240-221	20	251-241	22	297-050	23	323-324	21	410-211	19
229-121	12	240-306	19	251-243	22	297-075	23	323-326	21	410-306	20
230-101	6	240-351	6	251-311	22	297-100	23	323-328	21	410-321	20
230-201	6	240-353	6	251-321	22	297-150	23	323-330	21	413-171	26
230-201	6	240-361	6	251-351	22	297-200	23	323-332	21	413-173	26
230-221	6	241-101	19	251-401	22	297-250	23	323-334	21	413-175	26
230-301	6	241-401	19	251-501	22	298-056	23	323-336	21	413-177	26
230-311	6	242-101	19	254-151	22	298-079	23	323-508	21	413-179	26
230-321	6	242-106	19	254-501	22	298-090	23	323-510	21	413-181	26
230-501	6	242-111	19	254-506	22	298-203	23	323-512	21	413-183	26
230-511	6	242-116	19	260-101	24	299-001	24	323-514	21	413-185	26
230-511	6	242-131	19	260-151	24	299-011	24	323-516	21	413-187	26
230-521	13	242-136	19	261-108	24	299-013	24	323-518	21	413-191	25
230-531	2	242-141	19	261-110	24	299-015	24	323-520	21	413-193	25
230-531	3	242-151	19	261-112	24	299-017	24	323-522	21	413-201	25
235-101	2	242-181	19	261-116	24	299-036	24	323-524	21	413-203	25
235-102	2	242-191	19	261-118	24	299-041	24	323-526	21	413-205	25
235-103	2	243-101	20	281-022	23	299-101	24	323-528	21	413-209	25
235-104	2	243-106	20	281-050	23	299-111	24	323-530	21	413-211	25
235-105	2	243-111	20	281-100	23	299-118	24	323-532	21	413-213	25
235-201	4	243-116	20	283-013	23	299-121	24	323-534	21	413-215	25
235-202	4	243-121	20	283-035	23	299-131	24	323-536	21	413-217	25
235-203	4	243-126	20	283-065	23	299-141	24	323-538	21	413-219	25
235-204	4	243-131	20	283-100	23	299-146	24	323-540	21	413-221	25
235-205	4	243-136	20	285-013	23	299-151	24	323-542	21	413-223	25
235-301	5	243-141	20	285-030	23	299-166	24	323-548	21	413-225	25
235-302	5	243-146	20	285-060	23	323-110	21	323-560	21	413-227	25
235-303	5	243-161	20	285-090	23	323-112	21	323-612	21	413-229	25
235-304	5	243-166	20	285-120	23	323-114	21	323-614	21	413-260	25
235-305	5	243-171	20	287-035	23	323-116	21	323-616	21	413-261	25
235-306	5	243-176	20	287-045	23	323-118	21	323-618	21	413-262	25
235-307	5	243-191	20	287-060	23	323-120	21	323-620	21	413-263	25
235-308	5	243-196	20	287-080	23	323-122	21	323-622	21	413-264	25
235-309	5	251-111	22	287-097	23	323-124	21	323-624	21	413-265	25
235-310	5	251-121	22	287-135	23	323-126	21	323-626	21	413-266	25
235-701	3	251-131	22	289-030	23	323-128	21	323-628	21	413-267	25



Parts Index

Part	Page	Part	Page	Part	Page	Part	Page	Pièce	Page	Part	Page
413-270	25	414-529	26	501-804	35	515-612	36	545-608	38	590-261	28
413-271	25	414-531	26	501-806	35	515-614	36	545-610	38	590-266	28
413-272	25	414-533	26	501-808	35	515-616	36	545-612	38	590-361	28
413-273	25	414-535	26	501-810	35	515-618	36	545-614	38	607-101	31
413-274	25	414-537	26	501-812	35	521-602	37	545-616	38	607-111	31
413-275	25	414-539	26	501-814	35	521-603	37	545-618	38	607-341	31
413-276	25	414-541	26	501-816	35	521-604	37	551-604	39	607-351	31
413-277	25	414-543	26	505-603	35	521-606	37	551-607	39	610-007	31
413-280	25	414-545	26	505-604	35	521-608	37	551-806	39	610-014	31
413-281	25	414-547	26	505-606	35	521-610	37	551-810	39	610-046	31
413-282	25	414-549	26	505-608	35	521-612	37	552-604	39	610-053	31
413-283	25	418-101	27	505-610	35	521-614	37	552-607	39	610-092	31
413-284	25	418-102	27	505-612	35	521-802	37	552-806	39	610-102	31
413-285	25	418-103	27	505-614	35	521-804	37	552-810	39	610-111	31
413-286	25	418-104	27	505-616	35	521-806	37	553-604	39	610-127	31
413-287	25	418-105	27	505-618	35	521-808	37	553-607	39	611-151	31
413-291	25	418-111	27	506-602	35	521-810	37	553-806	39	612-131	31
413-293	25	418-112	27	506-603	35	531-602	37	553-810	39	612-141	31
413-295	25	418-113	27	506-604	35	531-603	37	555-101	39	612-161	31
413-299	25	418-114	27	506-606	35	531-604	37	555-106	39	612-501	31
413-400	26	418-121	27	506-608	35	531-606	37	555-111	39	612-521	31
413-401	26	418-122	27	506-610	35	531-608	37	555-116	39	612-541	31
413-403	26	418-123	27	506-612	35	531-610	37	555-121	39	612-551	31
413-405	26	418-124	27	506-802	35	531-612	37	575-216	28	625-008	31
413-409	26	418-125	27	506-804	35	531-614	37	575-251	28	625-012	31
413-421	26	418-126	27	506-806	35	531-802	37	575-252	28	625-022	31
413-423	26	418-131	27	506-808	35	531-804	37	575-253	28	625-096	31
413-425	26	418-132	27	506-810	35	531-806	37	575-501	28	625-106	31
413-427	26	418-134	27	511-602	36	531-808	37	575-502	28	626-001	32
413-429	26	418-135	27	511-603	36	531-810	37	575-503	28	626-003	32
413-433	26	418-136	27	511-604	36	541-602	38	575-651	28	626-124	32
413-435	26	418-137	27	511-606	36	541-603	38	575-652	28	626-130	32
413-437	26	418-138	27	511-608	36	541-604	38	575-653	28	626-136	32
413-439	26	418-139	27	511-610	36	541-606	38	575-731	28	652-101	29
413-441	26	465-100	20	511-612	36	541-608	38	575-732	28	652-201	29
413-443	26	465-109	20	511-614	36	541-610	38	575-733	28	652-601	29
413-445	26	465-115	20	511-616	36	541-612	38	575-735	28	652-806	29
414-501	26	465-121	20	511-618	36	541-614	38	575-751	28	652-811	29
414-503	26	465-131	20	511-802	36	541-616	38	575-752	28	653-101	29
414-505	26	465-141	20	511-804	36	541-618	38	575-753	28	653-111	29
414-507	26	501-602	35	511-806	36	541-802	38	575-754	28	653-121	29
414-509	26	501-603	35	511-808	36	541-804	38	575-758	28	653-141	29
414-511	26	501-604	35	511-810	36	541-806	38	580-122	28	675-111	30
414-513	26	501-606	35	511-812	36	541-808	38	590-101	28	675-126	30
414-515	26	501-608	35	511-814	36	541-810	38	590-106	28	675-206	30
414-517	26	501-610	35	511-816	36	541-812	38	590-201	28	675-211	30
414-519	26	501-612	35	515-603	36	541-814	38	590-206	28	675-221	30
414-521	26	501-614	35	515-604	36	541-816	38	590-211	28	675-226	30
414-523	26	501-616	35	515-606	36	545-603	38	590-216	28	675-236	30
414-525	26	501-618	35	515-608	36	545-604	38	590-251	28	675-241	30
414-527	26	501-802	35	515-610	36	545-606	38	590-256	28	675-306	30

